

1000 / 1000N

COMPRESSION FITTINGS

FOR COPPER PIPE

WITH BRASS OGIVE – THREADS ISO 7/1 (EN 10226)



DESCRIPTION

Tiemme compression fittings for copper pipes with brass ogive adapt to any type of heating/cooling and sanitation system, with application in residential, commercial, industrial and agricultural sectors and, in general, with any kind of non-corrosive fluid.

They are characterized by their sealing mechanism which is created by tightening the nut on the fitting body.

When the nut is tightened, the internal ogive is compressed between the nut and the main body of the fitting, thus ensuring the sealing of the system pressure.

The 1000/1000N series fittings are suitable for connecting copper pipes, or annealed copper pipe and PE-X pipe when used with the specific tube reinforcement bushes.

ADVANTAGES / STRENGTHS

- Brass ogive.
- Ample field of application; Water - Gas - Solar plants.
- Wide piping compatibility:
 - copper pipe
 - annealed copper pipe (using tube reinforcement bush art. 1116)
 - PE-X pipe (using tube reinforcement bush art. 1120).
- Wide range available for every installation need.

PRODUCT RANGE

Compression fittings for copper pipe with brass ogive are available in a wide range of sizes (from Ø 10 to Ø 28 mm), different shapes (straight, curved, T-shaped etc.), with different types of fittings (female threaded fittings, male threaded fittings, intermediate compression fittings etc...), to meet all kinds of system requirement.

See the HYDRAULIC COMPONENTS catalog for the full range.

MANUFACTURING SPECIFICATIONS

- | | |
|---|---|
| <ul style="list-style-type: none"> ▪ (1) Fitting body: ▪ (2) Nut: ▪ (3) Ogive: ▪ Threads: | <p>CW617N brass (1000 series)
Yellow/Nickel-plated CW617N brass (1000N series)</p> <p>CW617N brass (1000 series)
Yellow/Nickel-plated CW617N brass (1000N series)</p> <p>CW508L Brass</p> <p>F ISO 7/1 (EN 10226) straight
M ISO 7/1 (EN 10226) tapered</p> |
|---|---|

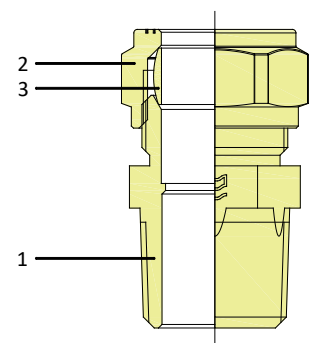

TECHNICAL SPECIFICATIONS

- | | |
|---|--|
| <ul style="list-style-type: none"> ▪ Maximum working temperature: ▪ Min working temperature: ▪ Maximum working pressure: ▪ Fluid compatibility: | <p>+ 200 °C *</p> <p>- 20 °C (provided the fluid remains in the liquid phase) *</p> <p>30 bar *</p> <p>Drinking water, water and glycol solutions (maximum percentage of glycol 30%) non-corrosive fluids **</p> |
|---|--|

* Consult section "COMPATIBILITY GUIDE" to check the performance limits and the application field according to the type of pipe used.

** Check compatibility with fluids or other substances not listed, contact Tiemme technical office.

COMPATIBILITY GUIDE

Series	Matching tube	Reinforcement bush	Field of application	Technical specifications
1000 / 1000N	Copper	-	<ul style="list-style-type: none"> Water Gas Solar systems 	Max. Temperature: 200°C Max. Pressure: 30 bar / 10 bar (with steam)
	Annealed copper	Art. 1116	<ul style="list-style-type: none"> Water Gas Solar systems 	Max. Temperature: 200°C Max. Pressure: 30 bar / 10 bar (with steam)
	PE-X	Art. 1120	<ul style="list-style-type: none"> Water 	Max. Temperature: 95°C Max. Pressure: 10 bar

INSTRUCTIONS FOR CORRECT ASSEMBLY

To obtain a perfect join between fitting/pipe, some simple but important operations must be carried out:

	<p>Cutting the pipe: The pipe must be cut with equipment suitable for obtaining a cut without burrs and perfectly perpendicular to the axis of the pipe.</p>																		
	<p>Burr-free cut and cleaning of the pipe: Deburr the pipe and clean it to remove residual chips.</p>																		
	<p>Insert the reinforcement sleeve into the pipe: Depending on the type of pipe, provide the appropriate reinforcement bush (if required):</p> <ul style="list-style-type: none"> - for copper pipe: reinforcement bush not required - for annealed copper pipe: bush art. 1116 - for PE-X pipe: bush art. 1120 																		
	<p>Connecting the pipe to the fitting: Grease ogive using a product suitable for the specific use of the plant (e.g. drinking water etc...) to allow a more plastic and homogeneous deformation.</p> <p>Place all the fitting components onto the pipe in the following order:</p> <ul style="list-style-type: none"> - nut (1) - pipe clamp ogive (2) <p>Nut tightening: Tighten the nut (1) on the body (2) as far as possible by hand and then with the help of a wrench, respecting the tightening turns shown in the table:</p> <table border="1"> <thead> <tr> <th>∅ ext. pipe (mm)</th> <th>10</th> <th>12</th> <th>15</th> <th>22</th> <th>28</th> </tr> </thead> <tbody> <tr> <td>no. of turns</td> <td>1 1/4</td> <td>1 1/4</td> <td>1 1/4</td> <td>1 1/4</td> <td>1</td> </tr> <tr> <td>tightening torque (Nm)</td> <td>15</td> <td>25</td> <td>70</td> <td>110</td> <td>125</td> </tr> </tbody> </table>	∅ ext. pipe (mm)	10	12	15	22	28	no. of turns	1 1/4	1 1/4	1 1/4	1 1/4	1	tightening torque (Nm)	15	25	70	110	125
∅ ext. pipe (mm)	10	12	15	22	28														
no. of turns	1 1/4	1 1/4	1 1/4	1 1/4	1														
tightening torque (Nm)	15	25	70	110	125														

IMPORTANT: Carrying out the following operations incorrectly may compromise the tightness of the joint.

TIEMME RACCORDERIE S.p.A. declines all responsibility in case of failures and/or accidents resulting from the non-compliance with these indications and from improper use of the system. The information shown does not exempt the user from scrupulously following current regulations and good technical standards.

NEVER:

- Use incompatible or harmful substances.
- Use these fittings for chased installation.

SOME POSSIBLE CAUSES OF LEAKS:

- Incorrect tightening of the nut onto the fitting (comply with the indications provided by Tiemme on the number of tightening turns).
- Excessive force used when tightening the nut.
- Connection with incompatible products.
- Incompatible fluids.
- Excessive use of sealants (e.g. hemp, PTFE tape etc...) on male/female threads could generate tension in the fittings.
- Freezing of the system or excessive internal pressure
- Storage of materials in unsuitable environments.
- Unpredictable external causes, such as accidental impacts or inappropriate movements.

MAIN ACCESSORIES OF THE SYSTEM

 <p>Art. 1116 Reinforcement bush for annealed copper pipe.</p>	 <p>Art. 1120 Reinforcement bush for PE-X pipe.</p>	 <p>Art. 1147 / 1147CZ Reducing bush.</p>
--	---	--

See the product catalog for order numbers / further details.

ITEM SPECIFICATION

1000 Series

Compression fitting for copper pipe with brass ogive, made from: CW617N brass body, CW617N brass nut, CW617N brass ogive, F ISO 7/1 (EN 10226) straight thread / M ISO 7/1 (EN 10226) tapered thread.

Maximum working temperature: + 200 °C. Min working temperature: - 20 °C (provided that the fluid remains in liquid phase). Maximum working pressure: 30 bar (10 bar with steam).

Piping compatibility: Copper tube, annealed copper tube (using tube reinforcement bush art. 1116), PE-X pipe (by using the reinforcing bush for pipe art. 1120).

Fluid compatibility: drinking water, water and glycol solutions (maximum percentage of glycol 30%), non-corrosive fluids.

Product range: from Ø 10 to Ø 28 mm, different configurations (straight, curved, T-shaped etc...) and with different types of fittings (female threaded fittings, male threaded fittings, intermediate compression fittings).

1000N Series

Compression fitting for copper pipe with brass ogive, made from: CW617N brass body, CW617N brass nut, yellow/nickel plated CW617N brass ogive, F ISO 7/1 (EN 10226) straight thread / M ISO 7/1 (EN 10226) tapered thread.

Maximum working temperature: + 200 °C. Min working temperature: - 20 °C (provided that the fluid remains in liquid phase). Maximum working pressure: 30 bar (10 bar with steam).

Piping compatibility: Copper tube, annealed copper tube (using tube reinforcement bush art. 1116), PE-X pipe (by using the reinforcing bush for pipe art. 1120).

Fluid compatibility: drinking water, water and glycol solutions (maximum percentage of glycol 30%), non-corrosive fluids.

Product range: from Ø 10 to Ø 28 mm, different configurations (straight, curved, T-shaped etc...) and with different types of fittings (female threaded fittings, male threaded fittings, intermediate compression fittings).

CERTIFICATIONS



ADDITIONAL PRODUCT RELATED INFORMATION

For more information related to this product, refer to the technical documentation mentioned below:

Type of document	Document code	Useful information available
Technical data sheet	1147	- Instructions for the use of accessory reducing bush art. 1147 and 1147CZ.