



**Double Regulating Valve**



***NexusValve***  
*Brevis*



**COMAP**  
**Flamco**



# Table of contents

## Chapter NexusValve Brevis

<b>1.</b>	<b>Safety instructions</b>	<b>4</b>
1.1	Rules/regulations	4
1.2	Intended use	5
1.3	Initial operation	5
1.4	Working on the system	5
1.5	Liability	5
<b>2.</b>	<b>Introduction</b>	<b>6</b>
2.1	Description	6
2.2	Benefits	6
2.3	Design	7
2.4	Flow setting	8
2.5	Operation	10
2.6	Mounting	11
2.6.1	Montagehinweise DN 15 – 50	11
2.6.2	Montagehinweise DN 65– 300	12
<b>3.</b>	<b>Applications</b>	<b>13</b>
<b>4.</b>	<b>Product data sheet</b>	<b>15</b>
4.1	Product finder	15
4.1.1	Product finder DN 15– 50	15
4.1.2	Productfinder DN 65 – 300	16
4.2	NexusValve Brevis DN15-50	17
4.2.2	DN 15-25 Female-/Female thread with Heat meter-Sensor connection	18
4.2.3	DN 15-25 Female-/Female thread with Heat meter-Sensor connection	19
4.3	Flow diagrams	23
<b>5.</b>	<b>Accessories</b>	<b>39</b>
5.1	NexusValve Brevis accessories	39
<b>6.</b>	<b>Sizing example</b>	<b>40</b>
6.1	NexusValve Vertex system sizing	40
6.2	General specifications DN 10-50	41

# 1. Safety instructions

**Please read the instructions carefully before installation**

The installation and initial operation of the assembly may be carried out only by an authorised specialist company.

Prior to starting work, familiarise yourself with all parts and how they are handled.

The application examples in these operating instructions are ideas sketched out. Local laws and regulations have to be observed.

**Target group:**

**These instructions are intended for authorised specialists exclusively.** Work on the heating system, the potable water as well as gas and power network may be carried out by specialists only.



**Please follow these safety instructions carefully in order to avoid hazards and damage to people and property.**

## 1.1 Rules/regulations

Please observe the applicable accident prevention regulations, the environmental legislation and the legal rules for mounting, installation and operation. Moreover, please observe the appropriate guidelines of German standard DIN, EN, DVGW, VDI and VDE (including lightning protection) as well as all current relevant country-specific standards, laws and regulations. Old and newly enforced regulations and standards shall apply, if they are relevant for the individual case. Moreover, the regulations of your local energy supply company have to be observed.

**Electrical connection:**

**Electrical wiring work may be carried out by qualified electricians only. The VDE regulations and the specifications of the relevant energy supply company have to be met.**

**Excerpt:****Installation and construction of heat generators as well as the drinking water heaters:**

DIN EN 4753, Part 1: Water heater and water heating plants for potable and process water.

DIN EN 12828 Heating systems in buildings.

Allowed medium (cf. DIN EN 12828): Heating water according to VDI 2035 (non-corrosive), water-glycol mixtures with up to max. 50% glycol content.

DIN 18 421: Insulation work on technical plants

AV B Wa s V Regulations concerning the general conditions for the supply with water

DIN EN 806 ff.: Technical rules for potable water installation

DIN 1988 ff.: Technical rules for potable water installation (national addition)

DIN EN 1717: Protection of potable water against contaminations

DIN 4751: Safety equipment

**Electrical connection:**

VDE 0100: Erection of electrical equipment, grounding, protective conductor, potential equalisation conductor.

VDE 0701: Repair, modification and testing of electrical devices.

VDE 0185: General aspects on the erection of lightning protection systems.

VDE 0190: Main potential equalisation of electrical plants.

VDE 0855: Installation of antenna plants (shall apply mutatis mutandis).

**Additional remarks:**

VDI 6002 Sheet 1: General principles, system technology and use in house building

VDI 6002, Sheet 2: Use in students' hostels, retirement homes, hospitals, indoor swimming pools and on camping facilities

**Caution:**

**Prior to any electrical wiring work on pumps and controls, these modules have to be disconnected from voltage correctly.**

## 1.2 Intended use

Inexpert installation as well as use for a purpose not intended of the assembly shall rule out all warranty claims.

All shut-off valves may be closed by an approved specialist only in case of servicing as otherwise the safety valves are not effective.



**Do not modify the electrical components, the construction or the hydraulic components! You will impair the safe function of the plant otherwise.**

## 1.3 Initial operation

Prior to the initial operation, the plant has to be tested for tightness, correct hydraulic connection as well as accurate and correct electrical connection. In addition, the plant has to be flushed correctly and/as required in keeping with German standard DIN 4753. The initial operation has to be carried out by a trained specialist, which has to be recorded in writing. In addition, the settings have to be put down in writing.

The technical documentation has to be available at the device.

## 1.4 Working on the system

**The plant has to be de-energised and to be checked for the absence of voltage (such as on the separate fuse or a master switch). Secure the plant against unintentional restart.**

(If gas is used as fuel, close the gas shut-off valve and secure against unintentional opening.) Repair work on component parts with a safety-relevant function is impermissible.

## 1.5 Liability

We reserve all copyrights for this document. Wrongful use, in particular reproduction and forwarding to third parties shall not be permitted.

These installation and operating instructions shall have to be handed to the customer. The executing and/or authorised tradesperson (such as fitter) shall have to explain the function and operation of the plant to the customer in an intelligible manner.

## 2. Introduction



### 2.1 Description

NexusValve Brevis is a variable orifice double regulating valve for balancing water-based heating and cooling systems. The balancing performed ensures the required distribution of flow in individual risers and terminal units. Applications are typically central heating or cooling systems, as well as fan coil units in multi-storey and high-rise buildings. NexusValve Brevis in sizes DN 15 - DN 50, is manufactured in dezincification resistant brass (DZR).

### 2.2 Benefits

- Product range from DN 15 to DN 300 for heating and cooling systems
- Pre-setting and isolation functions in one unit
- Compact design for installations in confined spaces
- Flow direction is irrelevant for the valve installation
- Pre-setting is fast and simple using an Allen key
- Setting scale is precise and easy to read
- Isolation of flow is simply done using the quarter-turn handle
- No change in pre-setting when isolated and re-opened

## 2.3 Design

The NexusValve Brevis comprises flow regulation and isolation functions in one unit. The regulation spindle inside the incorporated ball valve of the NexusValve Brevis enables setting of the valve independently of the isolation function of the ball valve. This allows the system flow to be isolated and re-opened again without losing the valve setting. Isolating the system flow is done by a simple quarter-turn of the NexusValve Brevis handle. The quarter-turn handle position makes it also easy to identify if the valve is open or closed. The compact design of NexusValve Brevis ensures that the valve fits perfectly even in confined spaces where access to the system is restricted. NexusValve Brevis is provided without measuring points. For systems where flow measurement is required NexusValve Fluctus or NexusValve Vertex should be used.



- 1 - Allen key for flow setting
- 2 - Regulating spindle
- 3 - Ball valve for flow isolation
- 4 - Isolation handle

NexusValve Brevis DN 65–300: butterfly valve provided with a gearbox with memory stop.



- Legend
- 1 - Setting wheel
  - 2 - Setting scale with memory stop
  - 3 - Gearbox
  - 4 - Butterfly valve

In connection with  
NexusValve Fluctus:  
5- Measuring point  
6- NexusValve Fluctus  
DN 65-300 with Venturi  
nozzle



## 2.4 Flow setting

The NexusValve Brevis is provided without measuring points and thus the flow cannot be validated directly. Based on calculations of pressure loss over a valve in a system and the required flow the valve setting can be evaluated. This can be then used for the system balancing.

The flow verification is possible in constant flow systems where NexusValve Brevis is installed in the by-pass pipe and NexusValve Vertex or NexusValve Fluctus at the terminal unit. Flowmeter can be then connected to the valves with measuring points and the required flow setting provided on the NexusValve Brevis.

## 2. Introduction

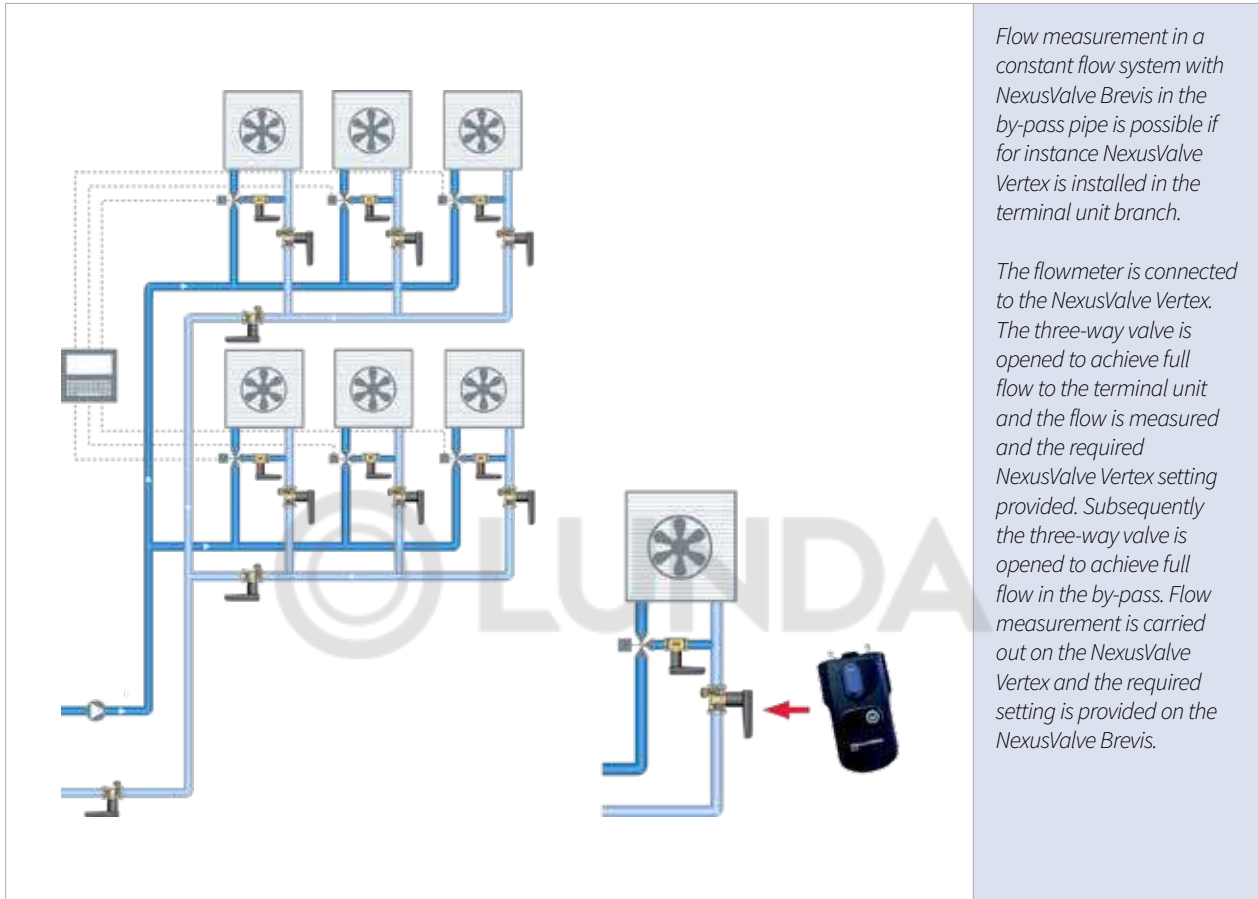

Setting is easily done using an Allen key to move the regulating spindle inside the valve and obtain its required position. The setting scale on top of the valve handle displays the precise setting for an – even from a distance – easy read-out.



NexusValve Brevis can be installed in any position, also regardless of the flow direction. This ensures a flexible and error-free installation with no limitation to supply or return line installations.



## 2.5 Operation

NexusValve Brevis is used as a stand-alone balancing valve to provide the desired flow distribution within the controlled system. The valve shall be installed at terminal units, in branches and risers.

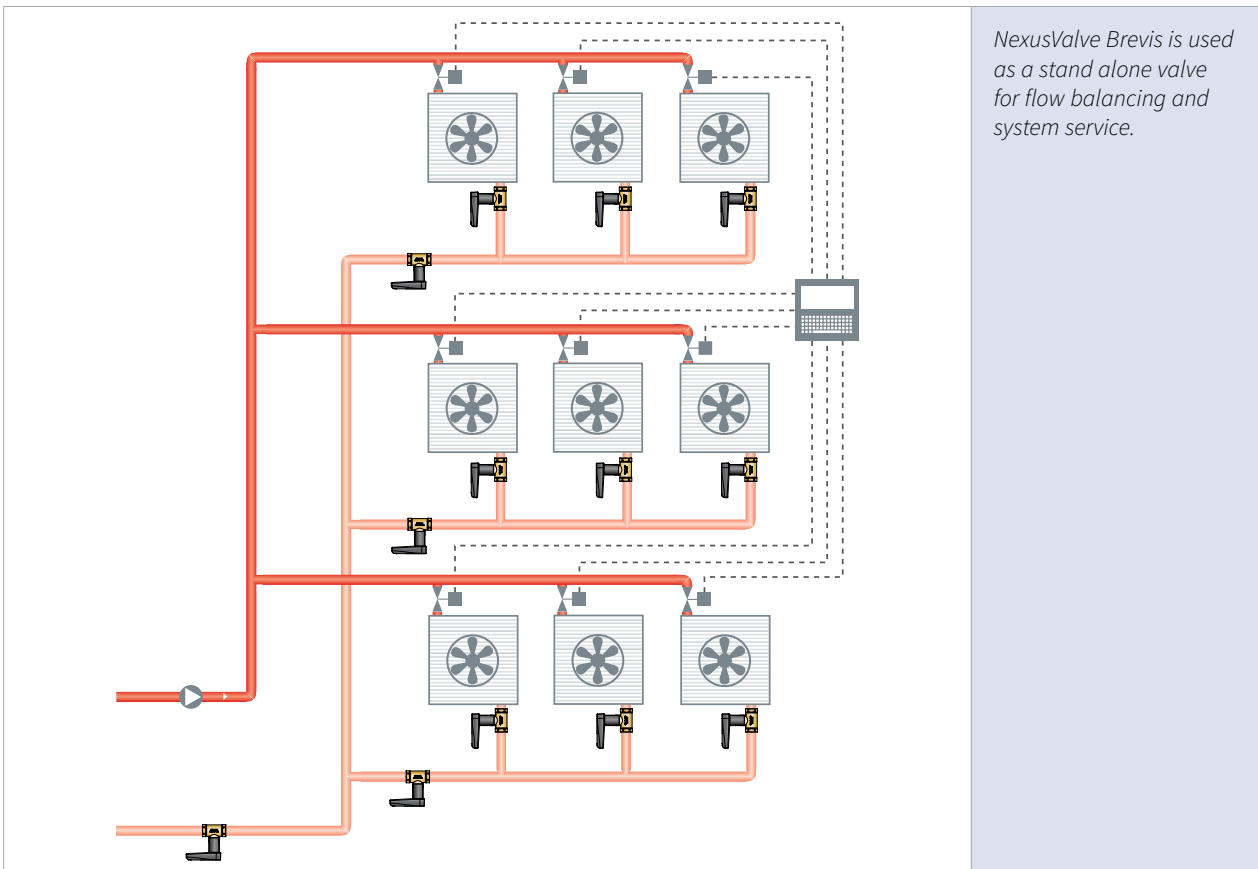



## 2. Introduction

### 2.6 Mounting

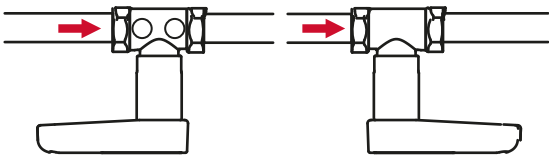
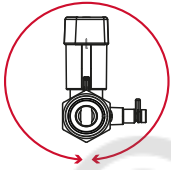
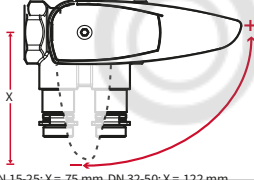
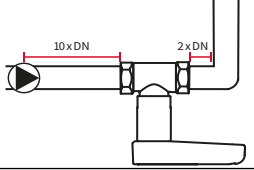
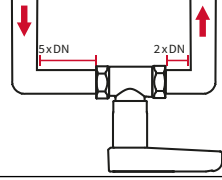
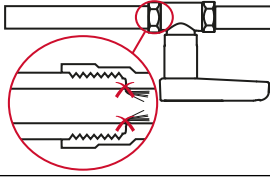
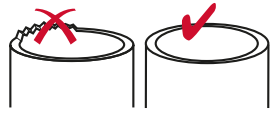
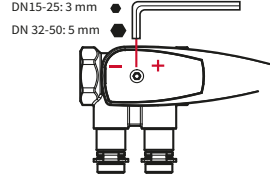
#### 2.6.1 Montagehinweise DN 15 – 50

	<p>NexusValve Brevis Ventile can be installed regardless of flow direction.</p>
	<p>The NexusValve Brevis can be orientated 360° around the pipe axis.</p>
 <p>DN 15-25: X = 75 mm DN 32-50: X = 122 mm</p>	<p>Installation space is required to ensure the 90° isolation.</p>
	<p>If a pump is installed immediately in front of the valve, a straight pipe of 10 × DN pipe diameter is required.</p>
	<p>NexusValve Brevis requires 5 × DN straight piping when installed directly after a bend, and 2 × DN straight piping when installed directly before a bend.</p>
	<p>Loose hems must not hang into the pipe.</p>
	<p>Deburring of pipe ends is required to prevent system clogging.</p>
 <p>DN15-25: 3 mm DN 32-50: 5 mm</p>	<p>Setting the valve is easily done using an Allen key. The valve is adjusted until the required flow is displayed on the flowmeter.</p>

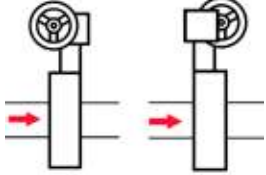
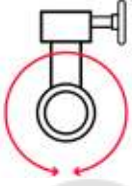
**2.6.2 Montagehinweise DN 65– 300**

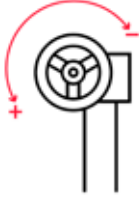
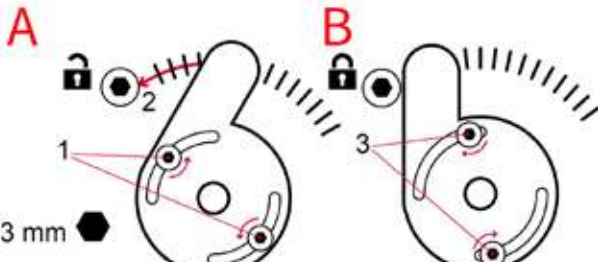
	<p>An arrow on the NexusValve Brevis indicates the flow direction to be respected.</p>
	<p>NexusValve Brevis can be installed with the gearbox pointing in any direction.</p>
	<p>There are no minimum requirements for straight lengths of pipe after the valve.</p>
	<p>The flow rate is adjusted by rotating the handle on the gearbox. The flow rate increases by rotating the handle to the left (counter-clockwise) and is reduced by rotating it to the right (clockwise).</p>
	<p><b>Memory-Stop:</b>          After determining the volume flow by opening or closing the butterfly valve, the handwheel can be blocked. The blocking grants a shut-off without changing the presetting.</p> <p>A: Loosen the screw (1) using a 3 mm Allen key. Turn the memory disk against the stop (2).          B: Fix the memory disk with screws (3)</p>

### 3. Applications

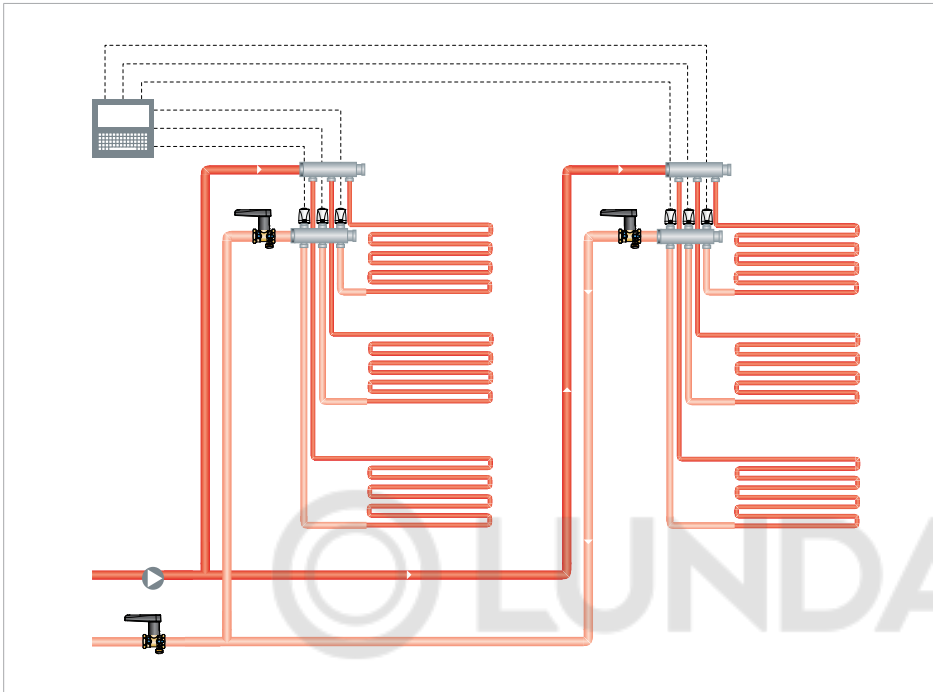

*Application 1 - Underfloor heating system*

*In an underfloor heating system NexusValve Brevis ensures the required flow distribution to all manifolds. Actuators connected to the room thermostat, or the BMS system, control the flow in each loop by opening or closing two-way valves in reference to the air temperature. The flow and temperature control ensure the required indoor thermal comfort.*

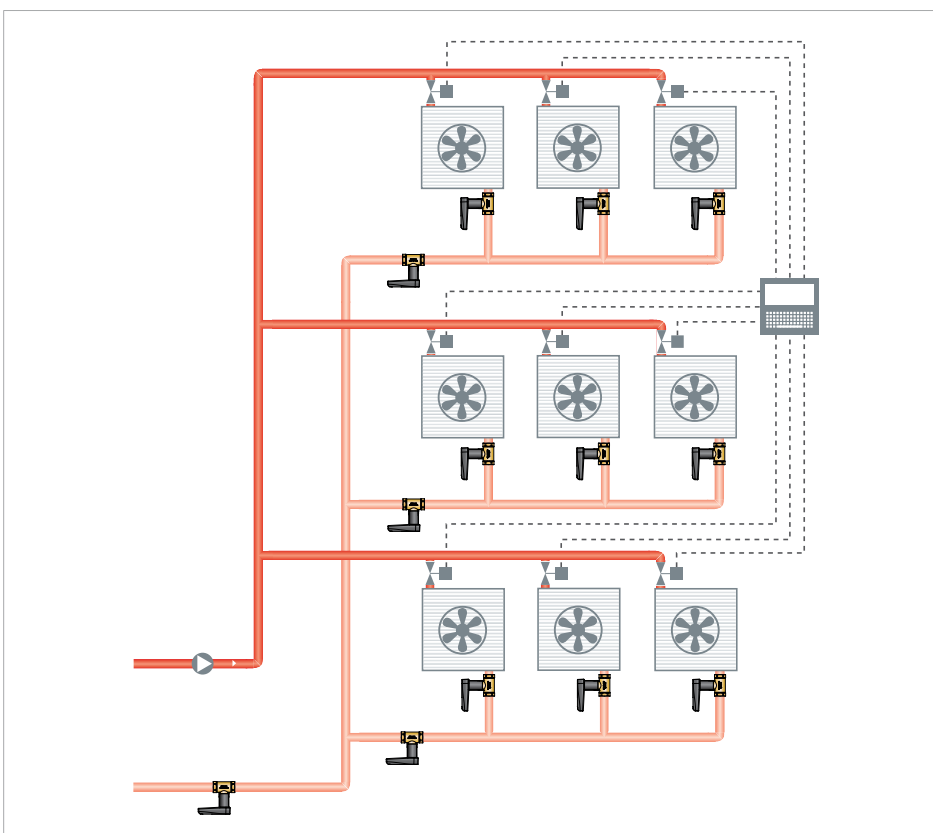

*Application 2 - Fan coil system with two-way motorized valves (variable flow system)*

*In a variable flow system with two-way motorized valves installed, the NexusValve Brevis provides hydronic balance and ensures that all fan coil units have the desired flow at maximum load conditions. Actuators installed on two-way motorized valves, connected to the room thermostat or BMS system, control the flow in each fan coil unit by opening or closing two-way valves in reference to the air temperature. The flow and temperature control ensures the required indoor thermal comfort.*

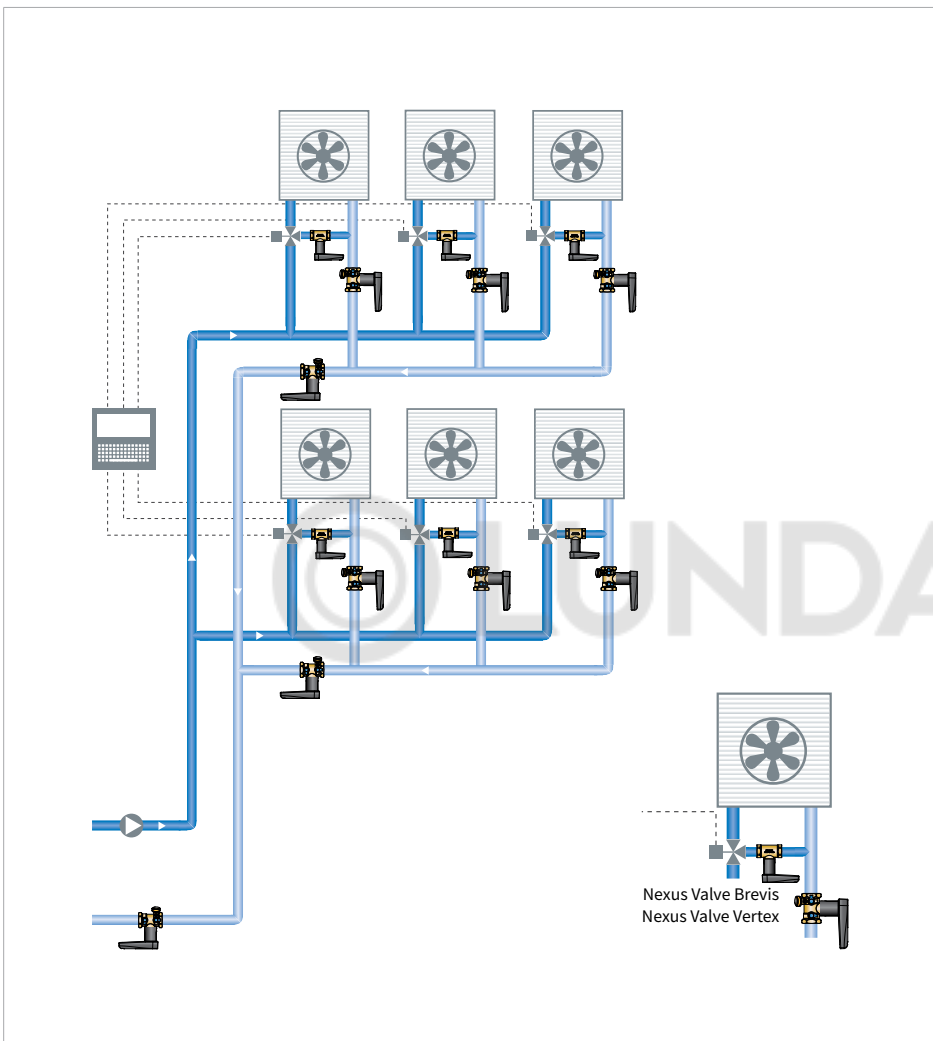

*Application 3 - Fan coil system with three-way motorized valves (constant flow system)*

*In a constant flow system with three-way motorized valves, the NexusValve Brevis provides hydronic balance during water flow through the by-pass. At the same time NexusValve Vertex ensures that all units have the required flow at maximum load conditions. This is possible as the NexusValve Brevis and NexusValve Vertex valves ensure the same pressure loss in the terminal unit branch regardless of the three-way valve position. Actuators installed on three-way motorized valves, connected to a room thermostat or BMS system, control the flow in each unit by opening or closing the three-way valves in reference to the air temperature. The flow and temperature control ensure the required indoor thermal comfort.*

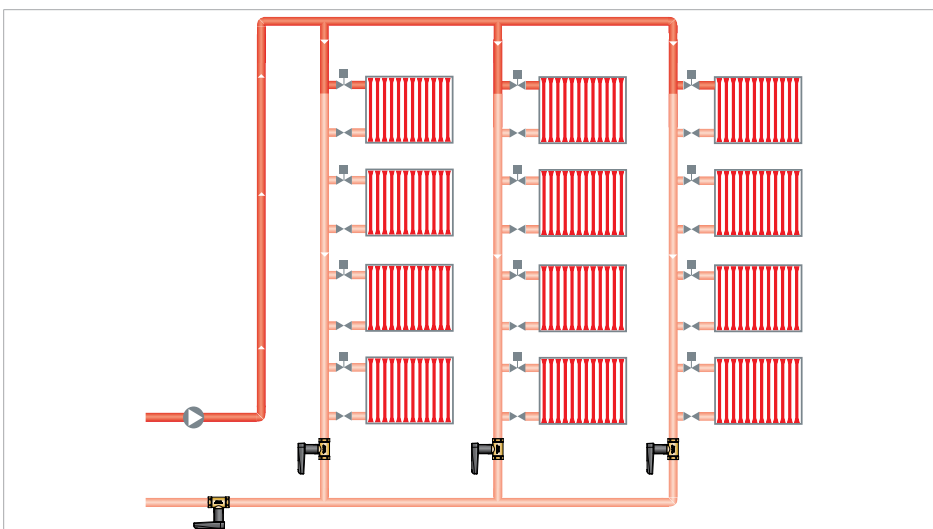

*Application 4 - One pipe heating system*

*The NexusValve Brevis installed in a one pipe heating system ensures the desired flow distribution through all branches and sections.*

## 4. Product data sheet

### 4.1 Product finder

#### 4.1.1 Product finder DN 15– 50

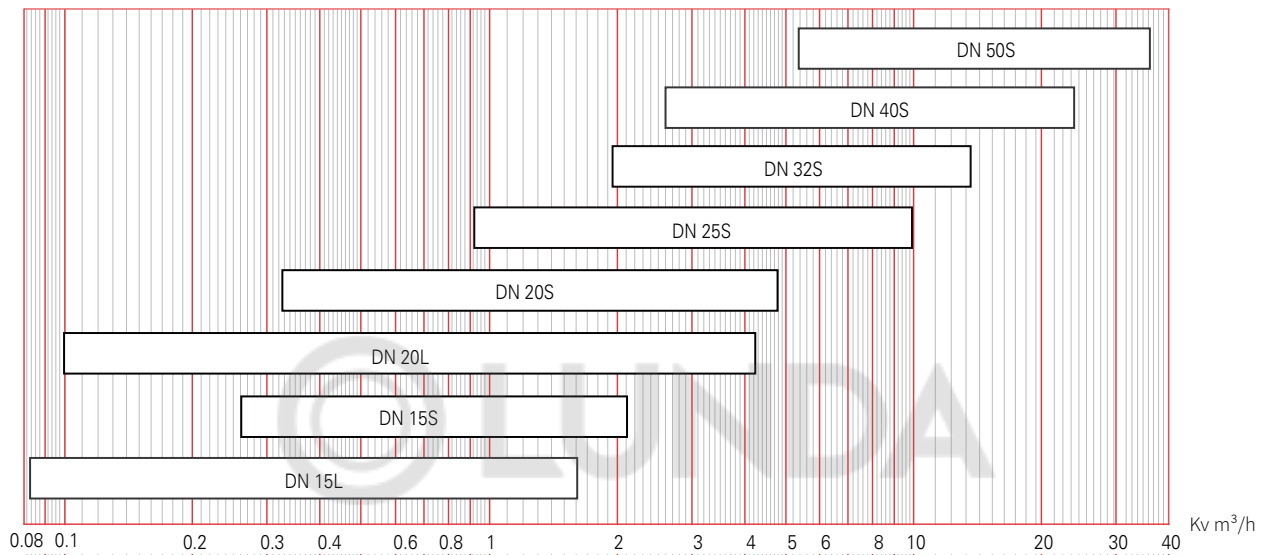

Flow range		Kvs m³/h	Dimension
l/s	l/h		
0.008-0.20	28.0-720	1.62	DN 15L
0.020-0.50	72.0-1800	2.11	DN 15S
0.020-0.50	72.0-1800	4.26	DN 20L
0.030-0.70	108-2520	4.81	DN 20S
0,080-2.00	288-7200	9.94	DN 25S
0.10-2.00	360-7200	13.3	DN 32S
0.10-3.00	360-10800	23.3	DN 40S
0.30-8.00	1080-28800	35.3	DN 50S

**4.1.2 Productfinder DN 65 – 300**

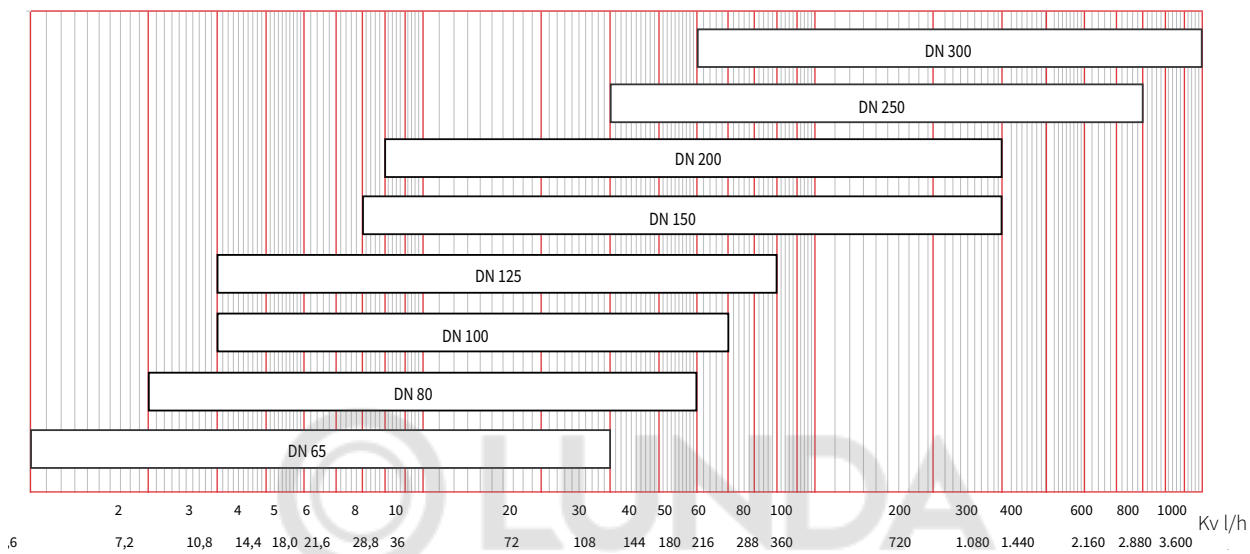

Flow range m³/h	Kvs m³/h	Dimension
18,34 - 148	148	DN 65
28,3 - 237	237	DN 80
14,1 - 603	603	DN 100
30,5 - 888	888	DN 125
71,9 - 2340	2340	DN 150
127 - 2845	2850	DN 200
234 - 4549	4550	DN 250
819 - 7761	7760	DN 300

## 4. Product data sheet

### 4.2 NexusValve Brevis DN15-50

#### 4.2.1 DN15-50 female/female

##### Dimensions

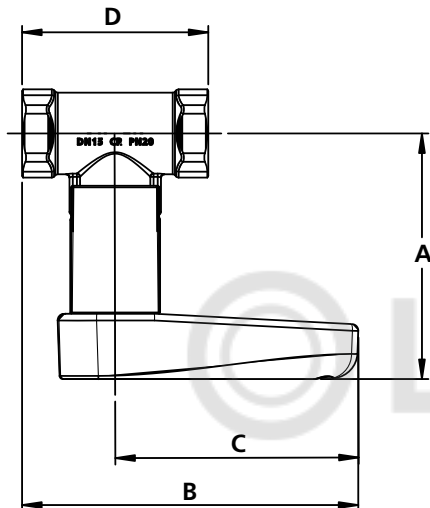

##### Specifications

<b>Max. temperature</b>	135°C
<b>Min. temperature</b>	-20°C
<b>Max. pressure</b>	PN25
<b>Marking on valve</b>	(Handle) DN (Valve body) DN, PN
<b>Connection</b>	Female thread ISO 7/1 parallel
<b>Valve housing</b>	DR Brass CW602N CuZn36Pb2As
<b>Ball and needle</b>	DR Brass CW602N (chrome plated)
<b>Valve handle</b>	Polyamide (PA6.6 30%GF)
<b>Sealings</b>	O-rings EPDM Gaskets PTFE Test point sealing EPDM

DN	A (mm)	B (mm)	C (mm)	D (mm)
15	76	104	75	57
20	79	106	75	62
25	83	113	75	75
32	109	166	122	88
40	113	171	122	98
50	120	180	122	115

**Note!** Information on insulation jackets, press adaptors and other is provided in the chapter Accessories.

**4.2.2 DN 15-25 Female-/Female thread with Heat meter-Sensor connection**

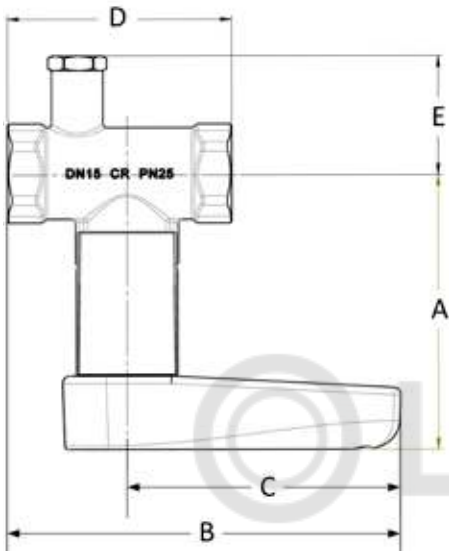
Dimensions	Specifications
	<p><b>Max. temperature</b> 135 °C  <b>Min. temperature</b> -20 °C  <b>Max. pressure</b> PN25  <b>Marking on valve</b> (Handle) DN                  (Valve body) DN, PN  <b>Connection</b> Female thread ISO 7/1 parallel  <b>Connection thread Heat meter-Connection</b> M10x1  <b>Valve housing</b> DR Brass CW602N                  CuZn36Pb2As  <b>Ball and needle</b> DR Brass CW602N (chrome plated)  <b>Valve handle</b> Polyamide (PA 6,6 30 % GF)  <b>Sealings</b> O-Rings EPDM                  Sealings PTFE                  Test point sealing EPDM</p>

DN	A (mm)	B (mm)	C (mm)	D (mm)	E (mm)	SW
15	75	104	75	57	32	27
20	78	106	75	62	32	32
25	82	113	75	75	32	40

**Note!** Information on insulation jackets, press adaptors and other is provided in the chapter Accessories.

### 4.2.3 DN 15-25 Female-/Female thread with Heat meter-Sensor connection

#### Dimensions

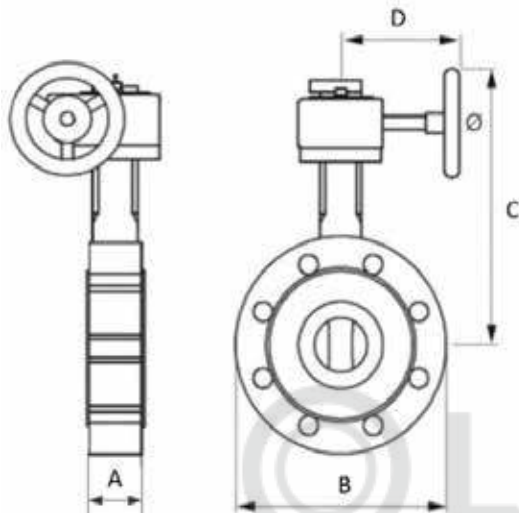





#### Specifications

<b>Max. temperature</b>	120°C
<b>Min. temperature</b>	-20 °C
<b>Max. pressure</b>	PN16
<b>Marking on valve, Butterfly gearbox</b>	Valve type, DN, Kvs
<b>Connection</b>	Flange/Flange: EN 1092-1 PN16
<b>Material</b>	Valve body: Cast iron fully lugged (ASTM A126 KL. B) Disc and shaft: Stainless steel (ASTM A351)
<b>Sealings</b>	EPDM and NBR, on site

DN	A (mm)	B (mm)	C (mm)	D (mm)	Nr. of Bolts
65	45	185	270	165	4
80	46	200	275	165	8
100	52	220	310	165	8
125	55	250	320	165	8
150	56	285	320	165	8
200	60	340	390	165	12
250	68	405	485	230	12
300	78	460	530	230	12

Valve	Article	Nom. Inch	Kvs m <sup>3</sup> /h	Flow range l/h
<b>DN 15L</b>				
	MN80597.441	½"	1.62	28.0-720
<b>DN 15S</b>				
	MN80597.442	½"	2.11	72.0-1800
<b>DN 20L</b>				
	MN80597.443	¾"	4.26	72.0-1800
<b>DN 20S</b>				
	MN80597.444	¾"	4.81	108-2520
<b>DN 25S</b>				
	MN80597.445	1"	9.94	288-7200
<b>DN 32S</b>				
	MN80597.446	1 ¼"	13.3	360-7200
<b>DN 40S</b>				
	MN80597.447	1 ½"	23.3	360-10800
<b>DN 50S</b>				
	MN80597.448	2"	35.3	1080-28800

Valve	Article	Nom. Inch	Kvs m <sup>3</sup> /h	Flow range l/h
<b>DN 15L</b> 	MN80597.491	Rp ½" IG x IG	1,62	28 - 720
<b>DN 20L</b> 	MN80597.493	Rp ¾" IG x IG	4,26	72 - 1800
<b>DN 25S</b> 	MN80597.493	Rp ¾" IG x IG	4,26	72 - 1800

Valve	Article	Nom. Inch	Kvs m <sup>3</sup> /h	Flow range m <sup>3</sup> /h	Nr. of Bolts	ca. Gewicht kg
<b>DN 65</b> 	MN80597.4710	2 ½"	148	18,34-148	4	5,93
<b>DN 80</b> 	MN80597.4720	3"	237	28,3-237	8	6,07
<b>DN 100</b> 	MN80597.4730	4"	603	14,1-603	8	8,7
<b>DN 125</b> 	MN80597.4740	5"	888	30,5-888	8	11,2

# NexusValve

Brevis

## DN 150



MN80597.4750	6"	2340	71,9-2340	8	12,86
--------------	----	------	-----------	---	-------

## DN 200



MN80597.4760	8"	2850	127-2845	12	20,33
--------------	----	------	----------	----	-------

## DN 250



MN80597.4770	10"	4550	234-4549	12	32,6
--------------	-----	------	----------	----	------

## DN 300



MN80597.4780	12"	7760	819-7761	12	53
--------------	-----	------	----------	----	----

**Note!** For DN15-50 Information on insulation jackets, press adaptors and other is provided in the chapter Accessories.

## 4. Product data sheet

### 4.3 Flow diagrams

The graph is used to determine the total pressure loss across the NexusValve Brevis valve at a given pre-setting and flow rate. The minimum digital scale setting is 0.0 and the maximum setting (fully open valve) is 9.9. One hundred different positions, at an increment of 0.1, are possible, and each position corresponds to a different Kv value. The Kv value and the Kvs value (at a fully open valve) refer to the pressure loss across the entire valve. These values are used for system sizing and pump selection. A pressure loss of up to 100 kPa is allowed across the NexusValve Brevis valve. Within the working range it should be assured that cavitation does not occur at any given pressure loss. Valve sizing example is provided in chapter 6.

#### DN 15L

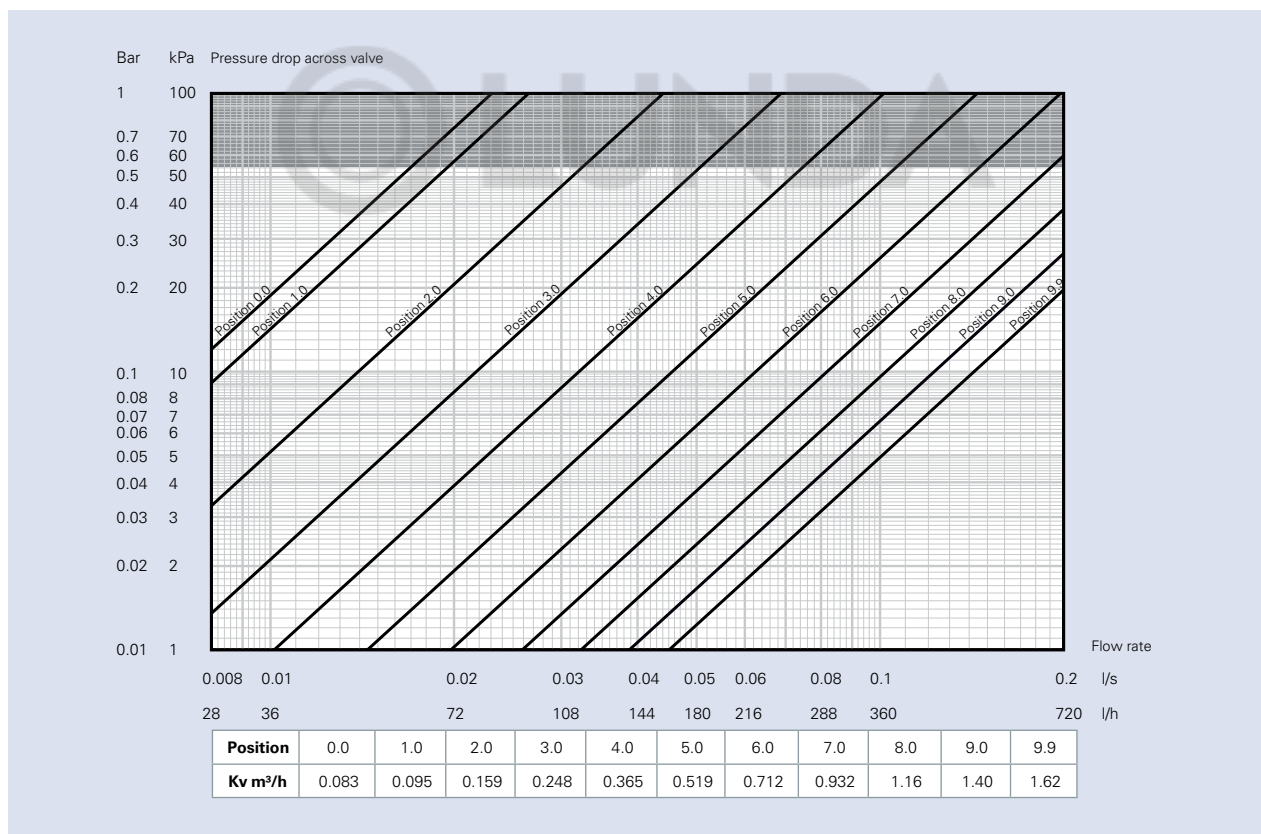

### DN 15S

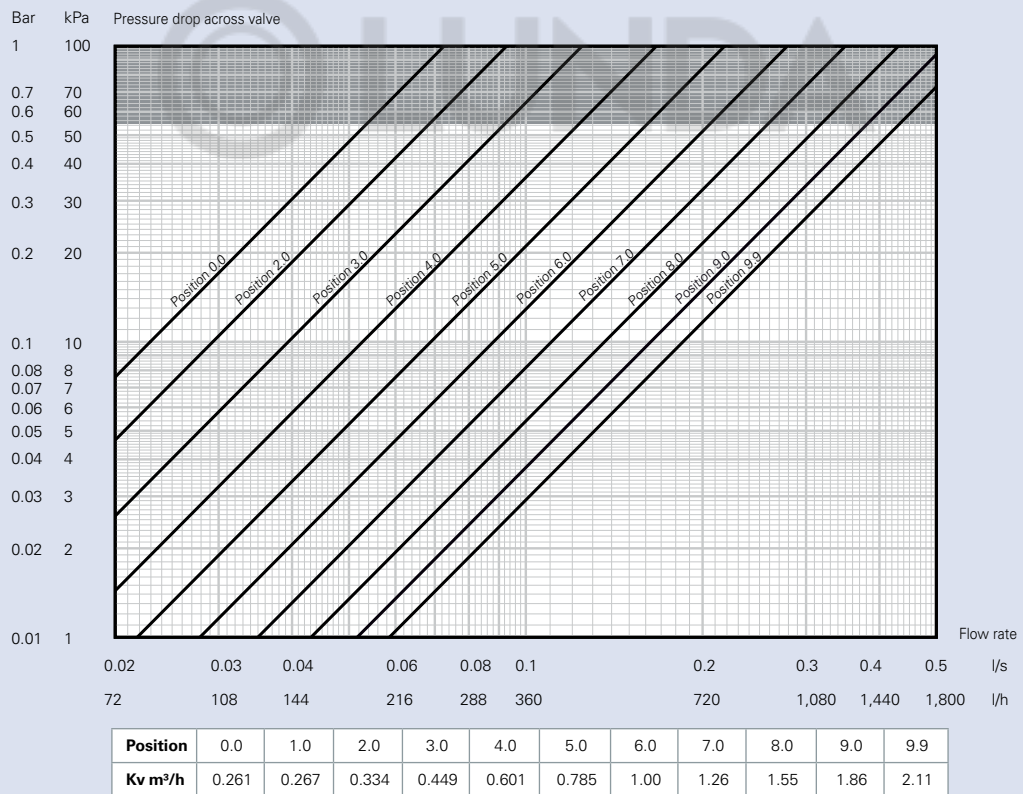

**DN 20L**

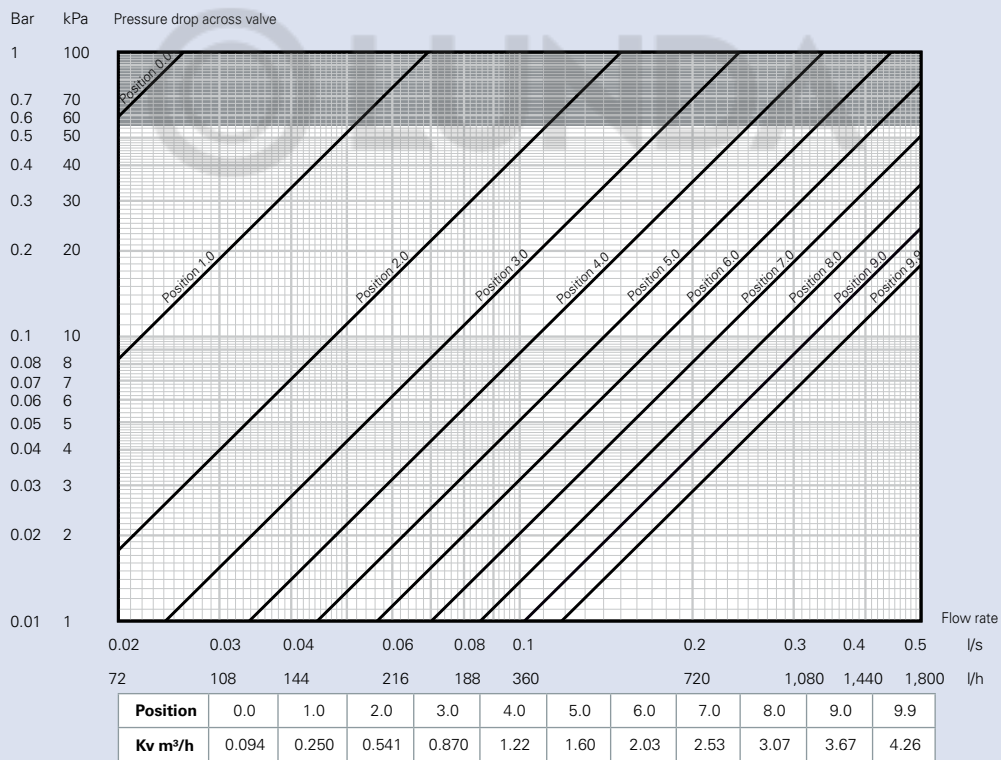

## DN 20S

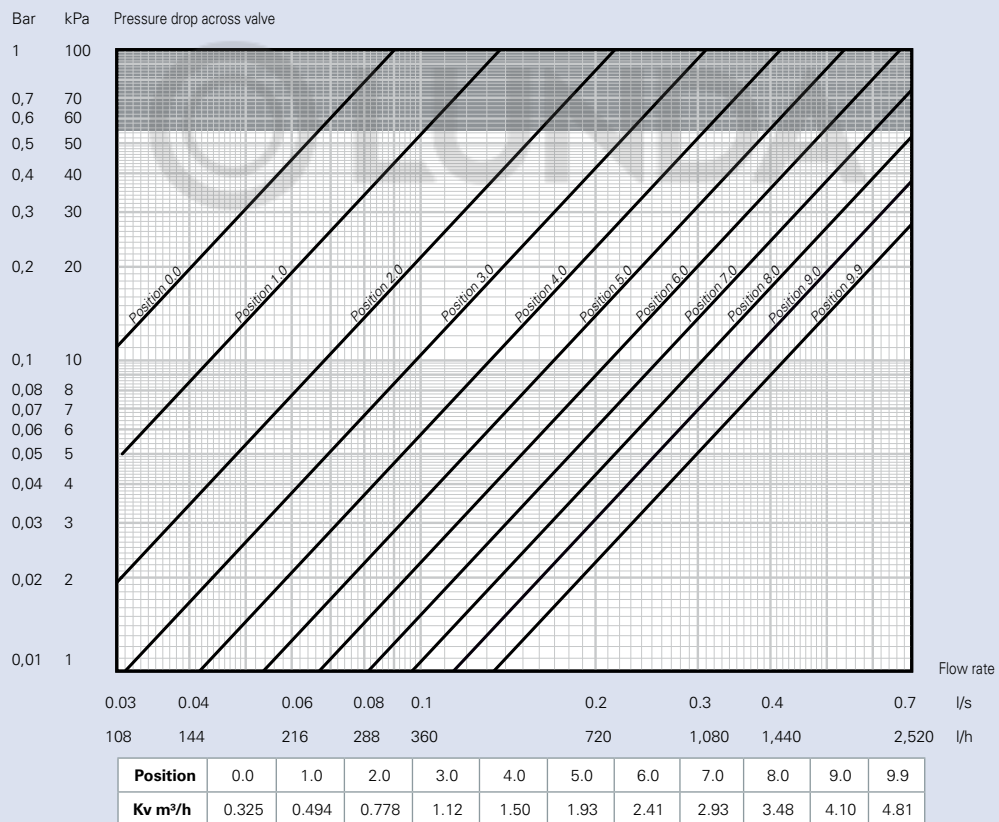

# 4. Product data sheet

## DN 25S

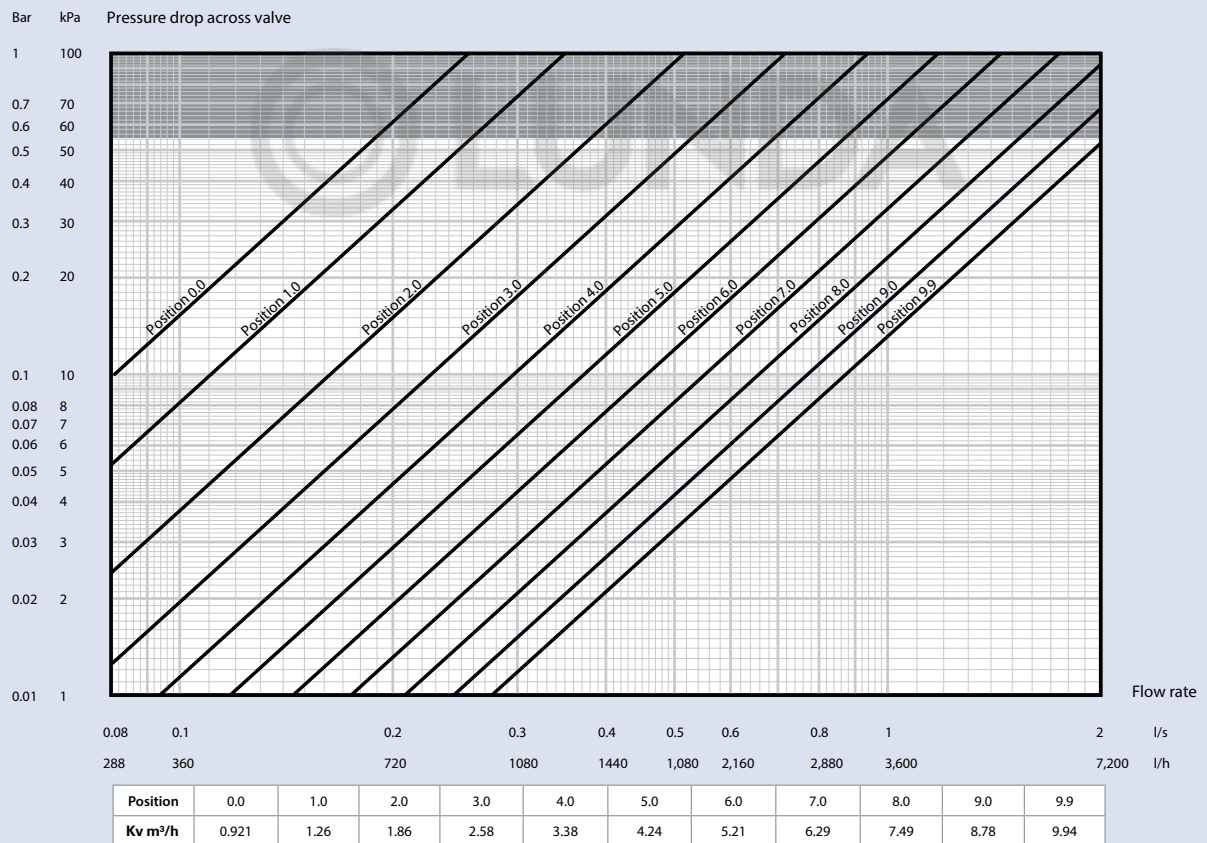

### DN 32S

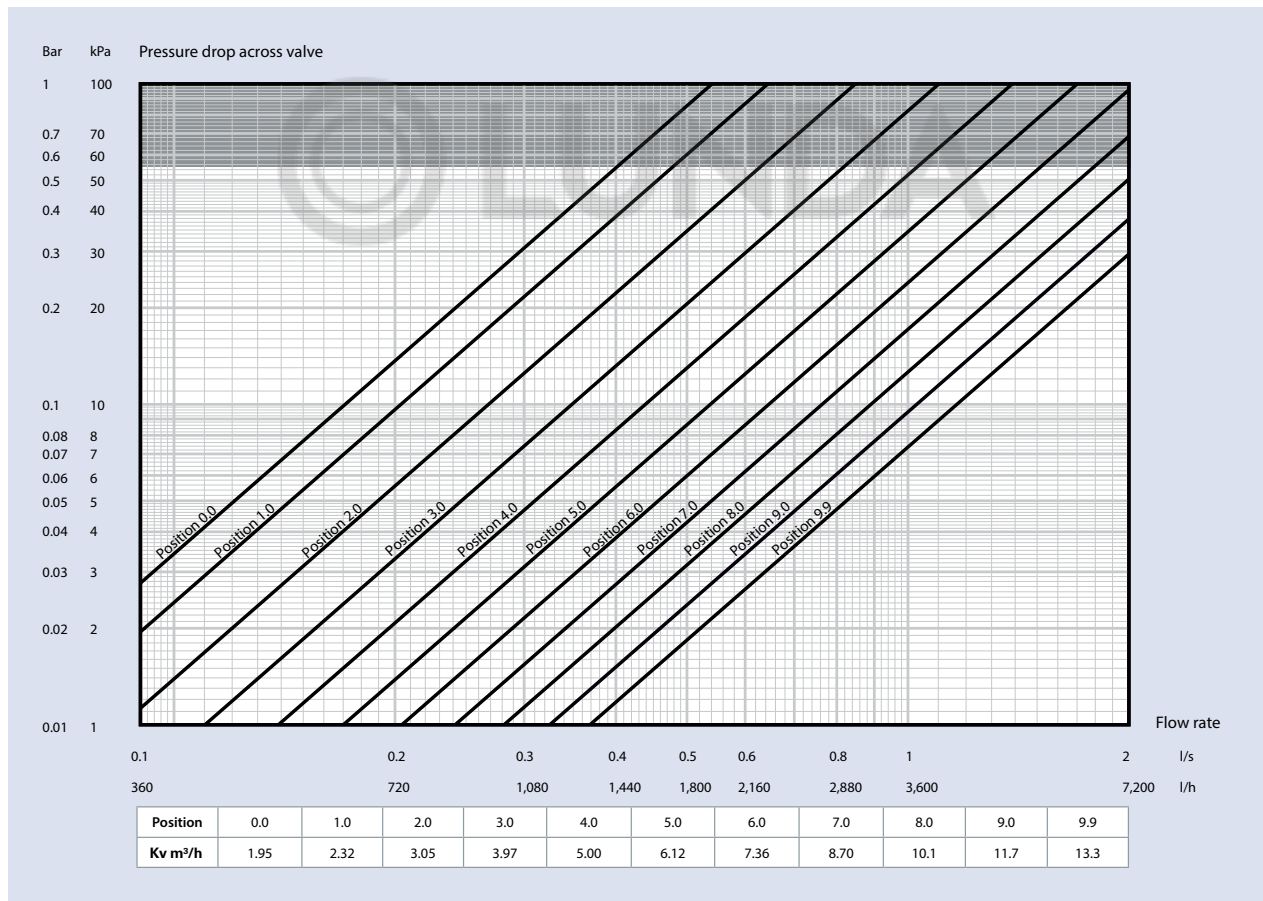

## 4. Product data sheet

### DN 40S

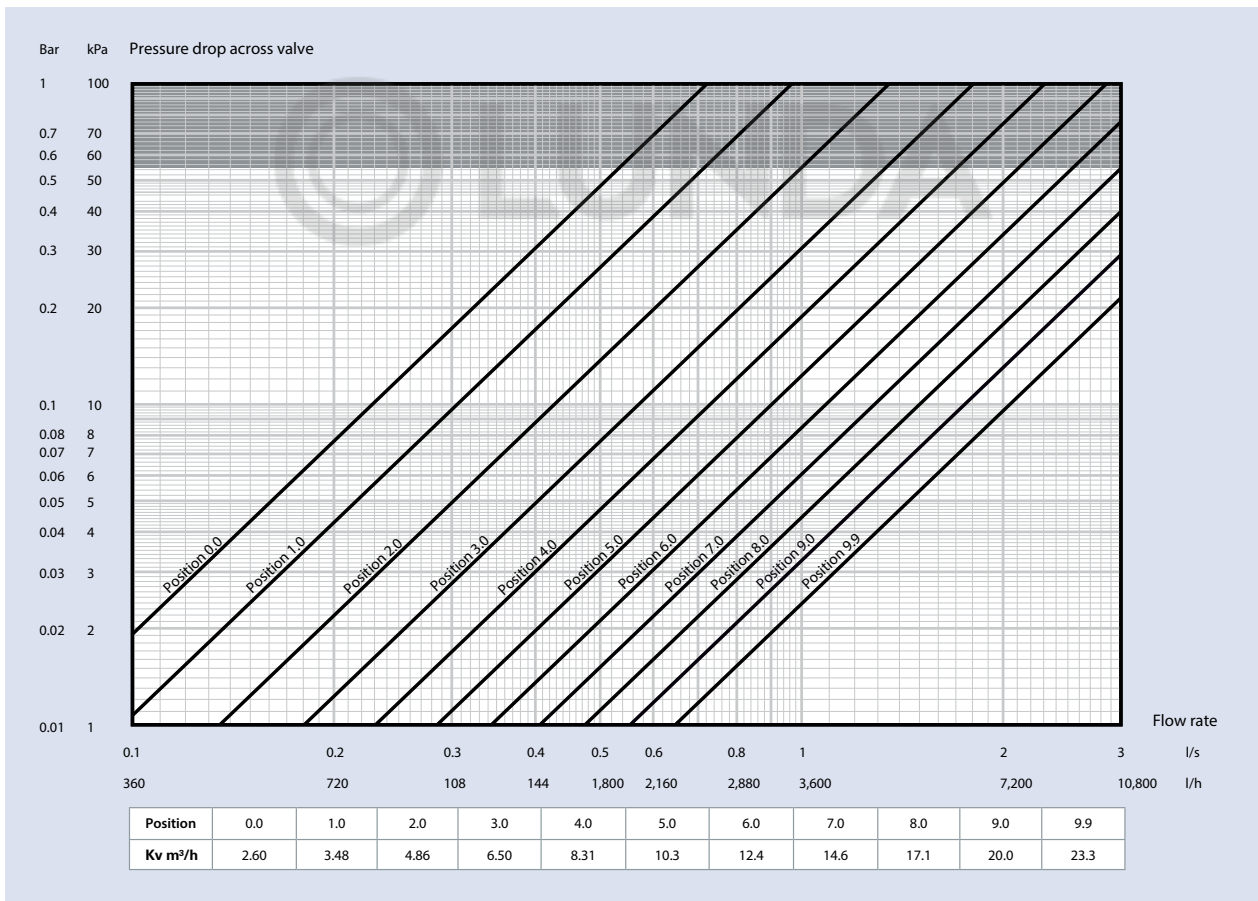

### DN 50S

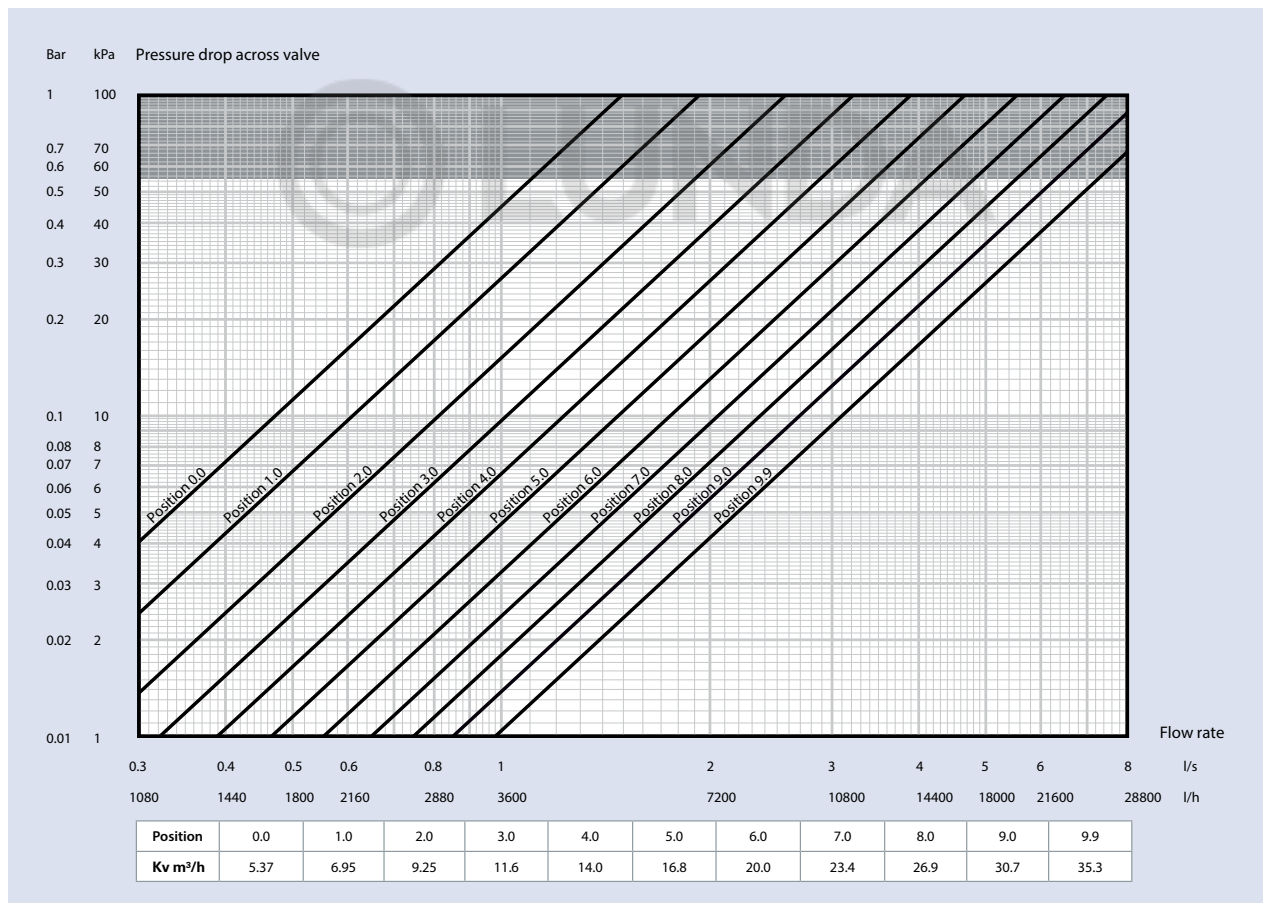

**DN 65**

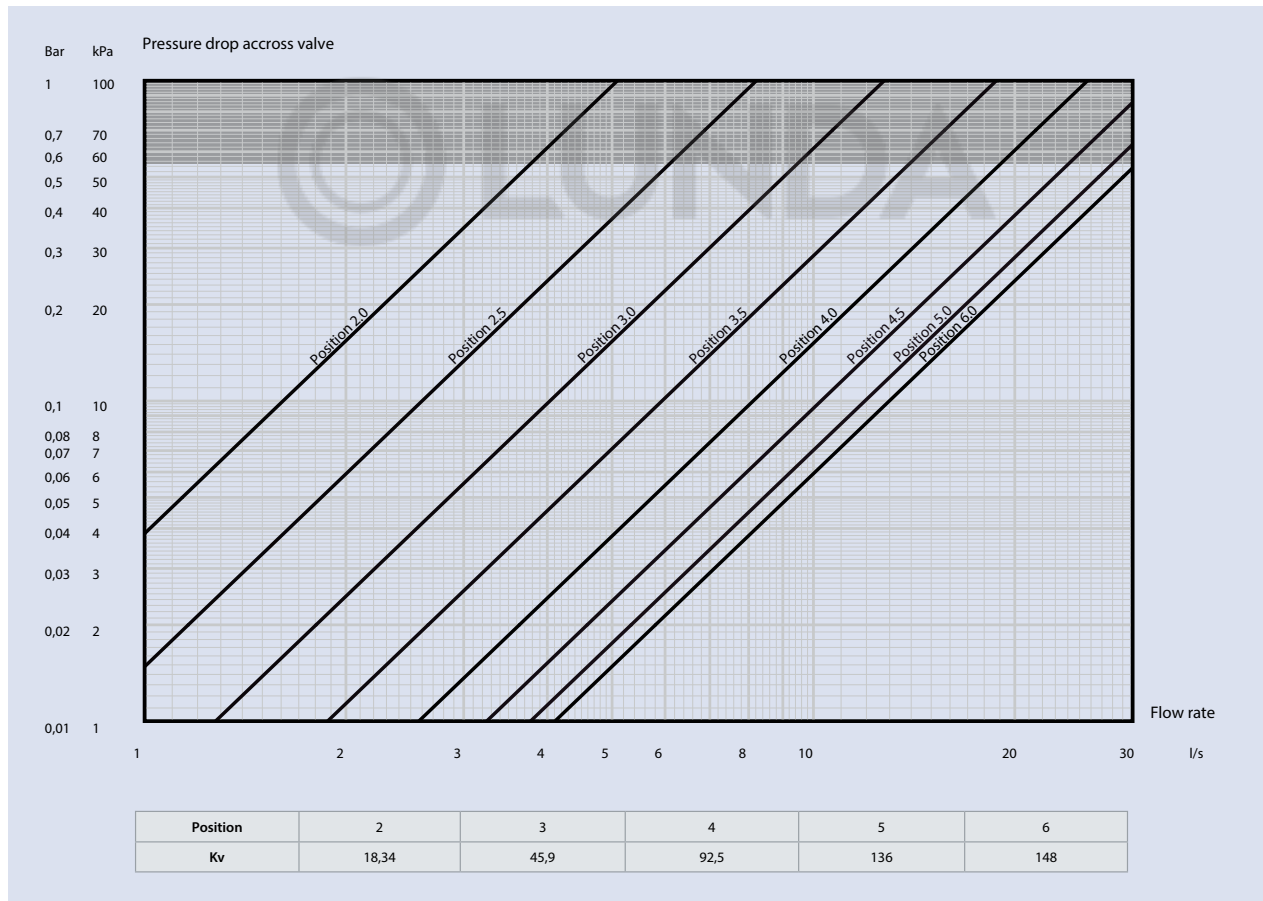

## DN 80

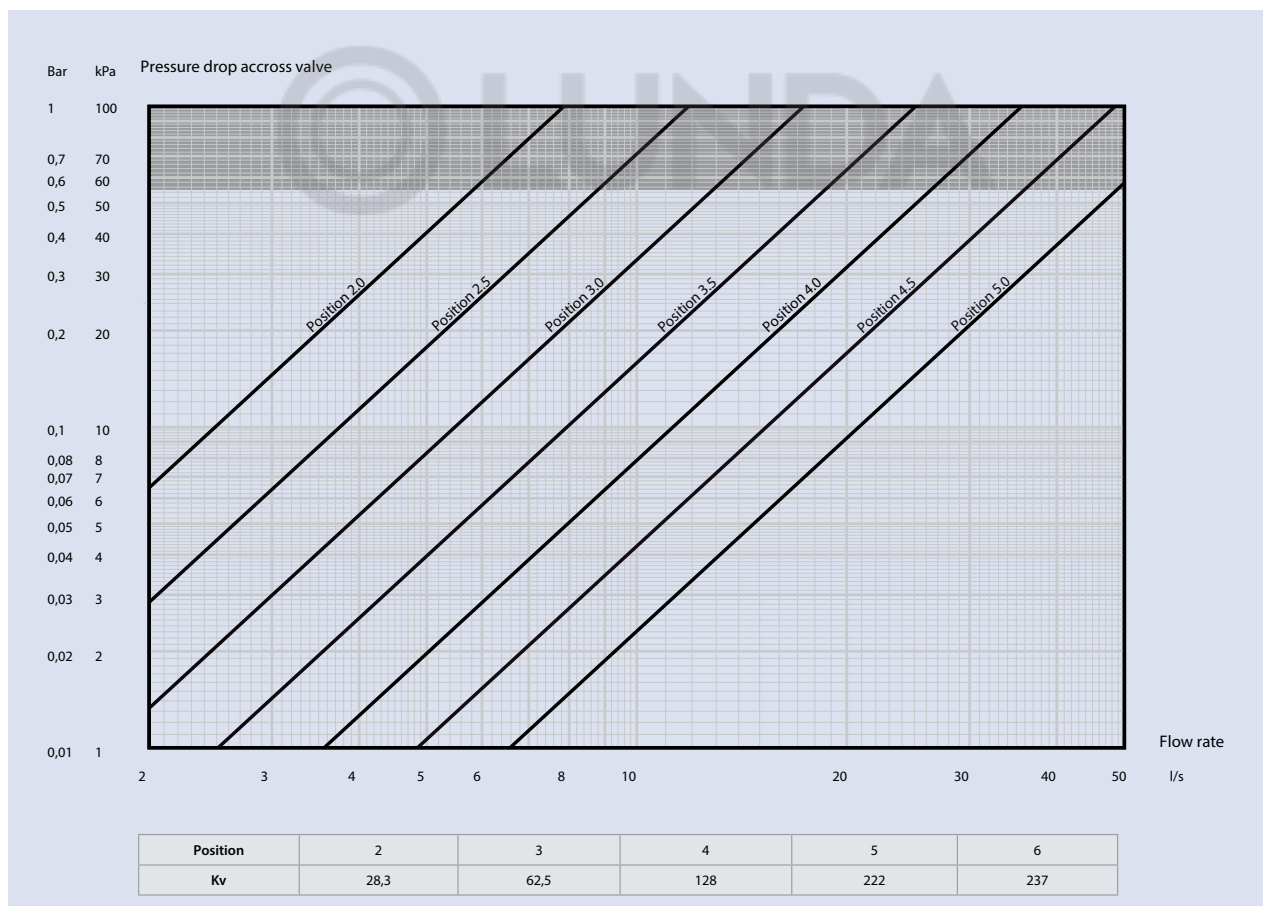

**DN 100**

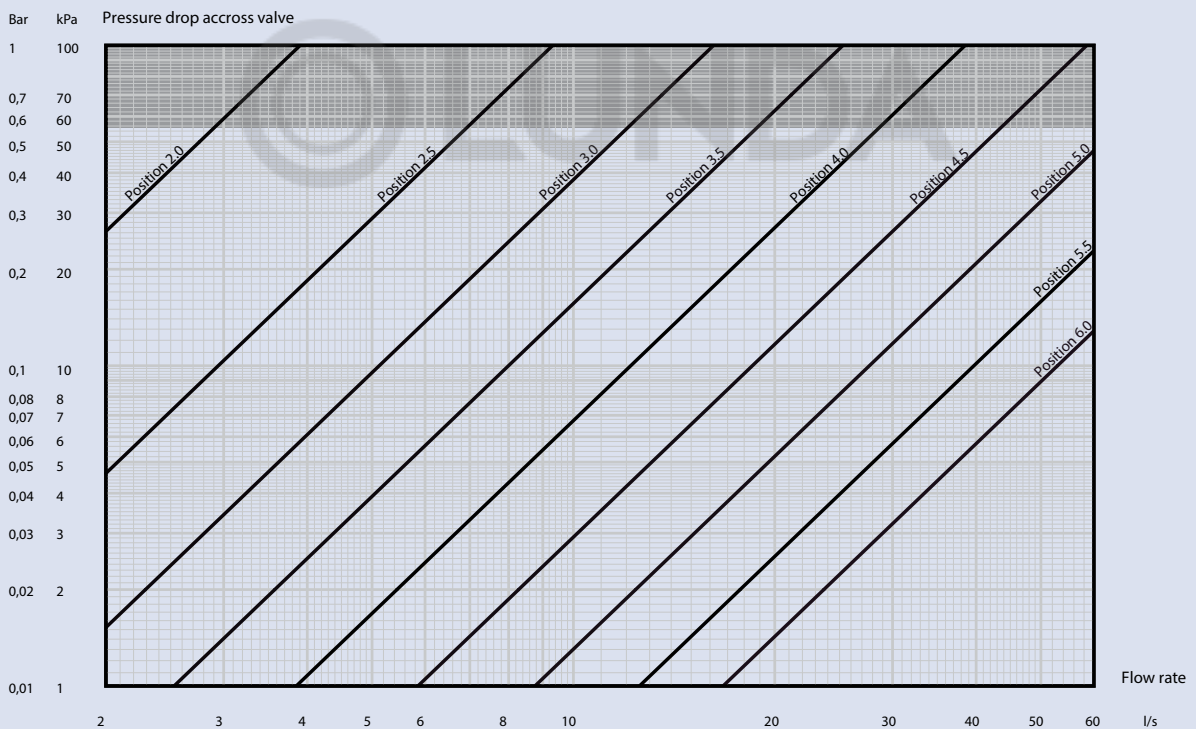

Position	2	3	4	5	6
Kv	14,1	58,3	139	315	603

## DN 125

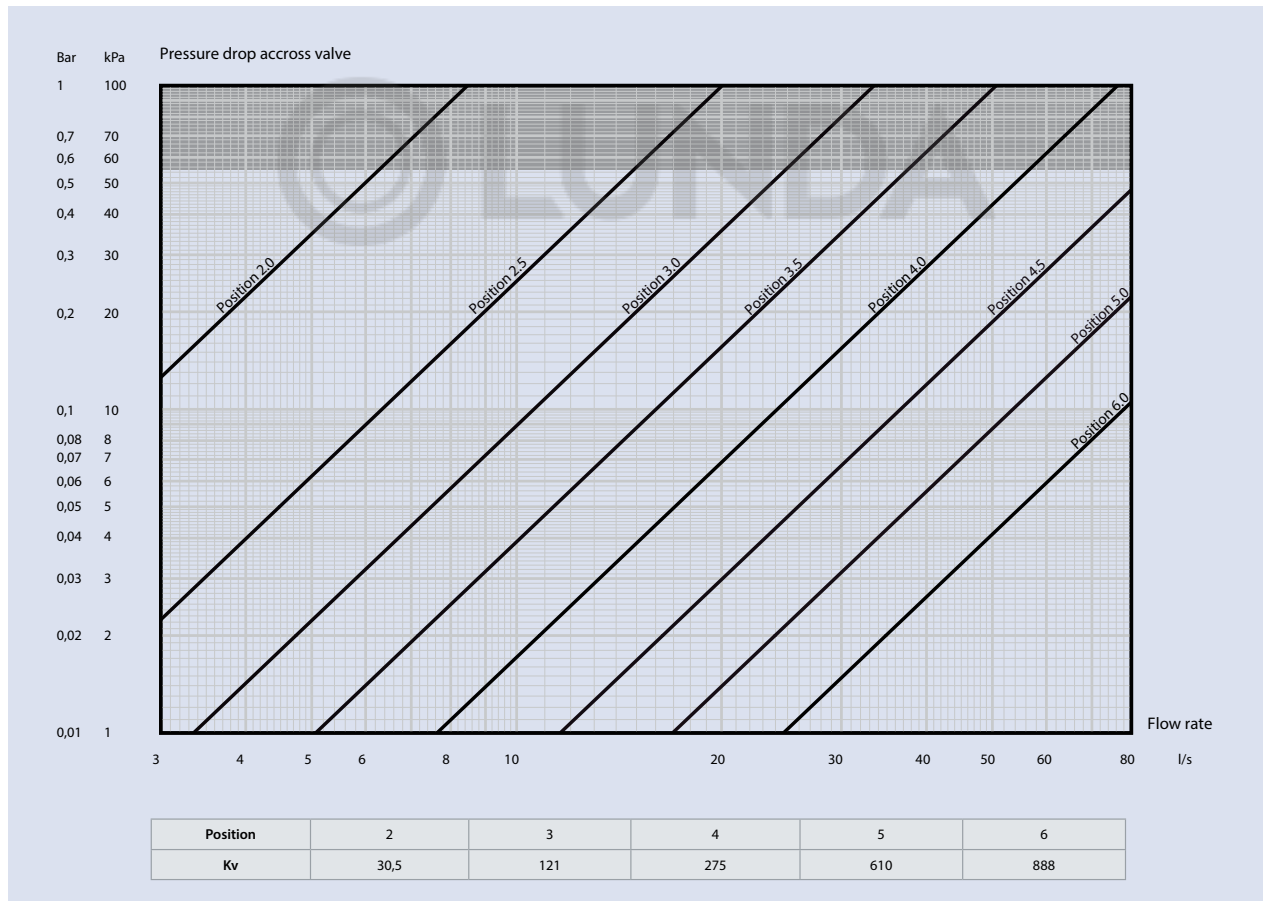

**DN 150**

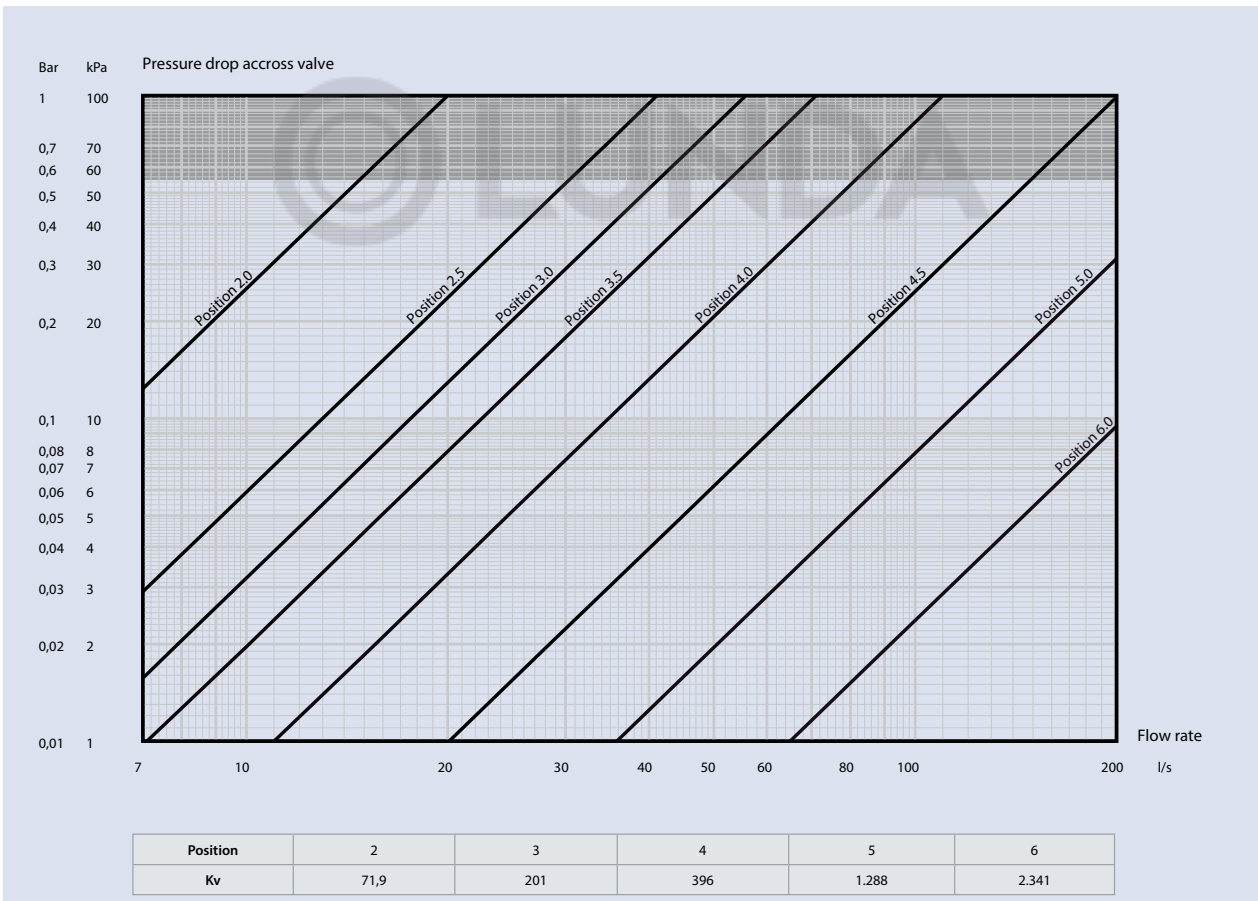

### DN 200

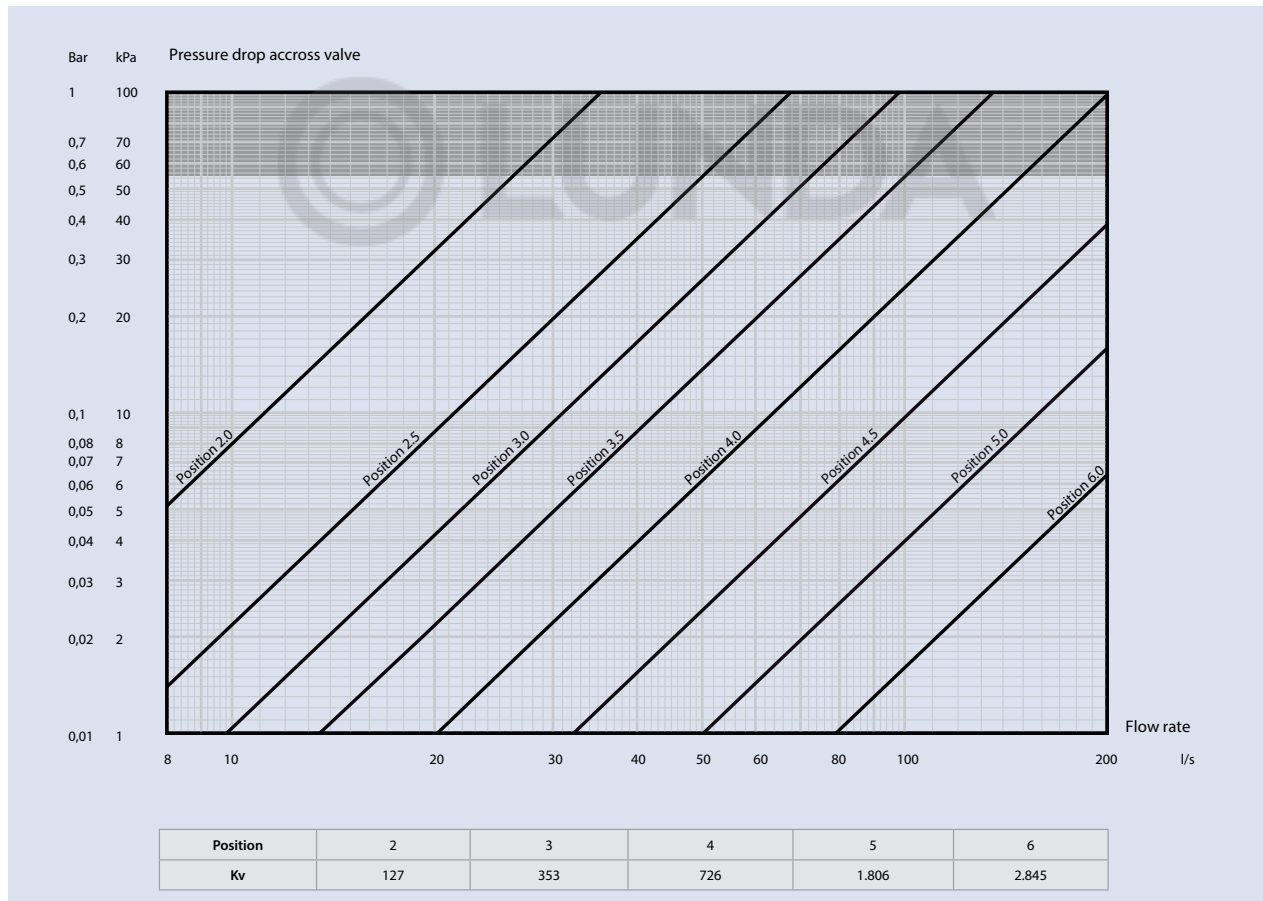

**DN 250**

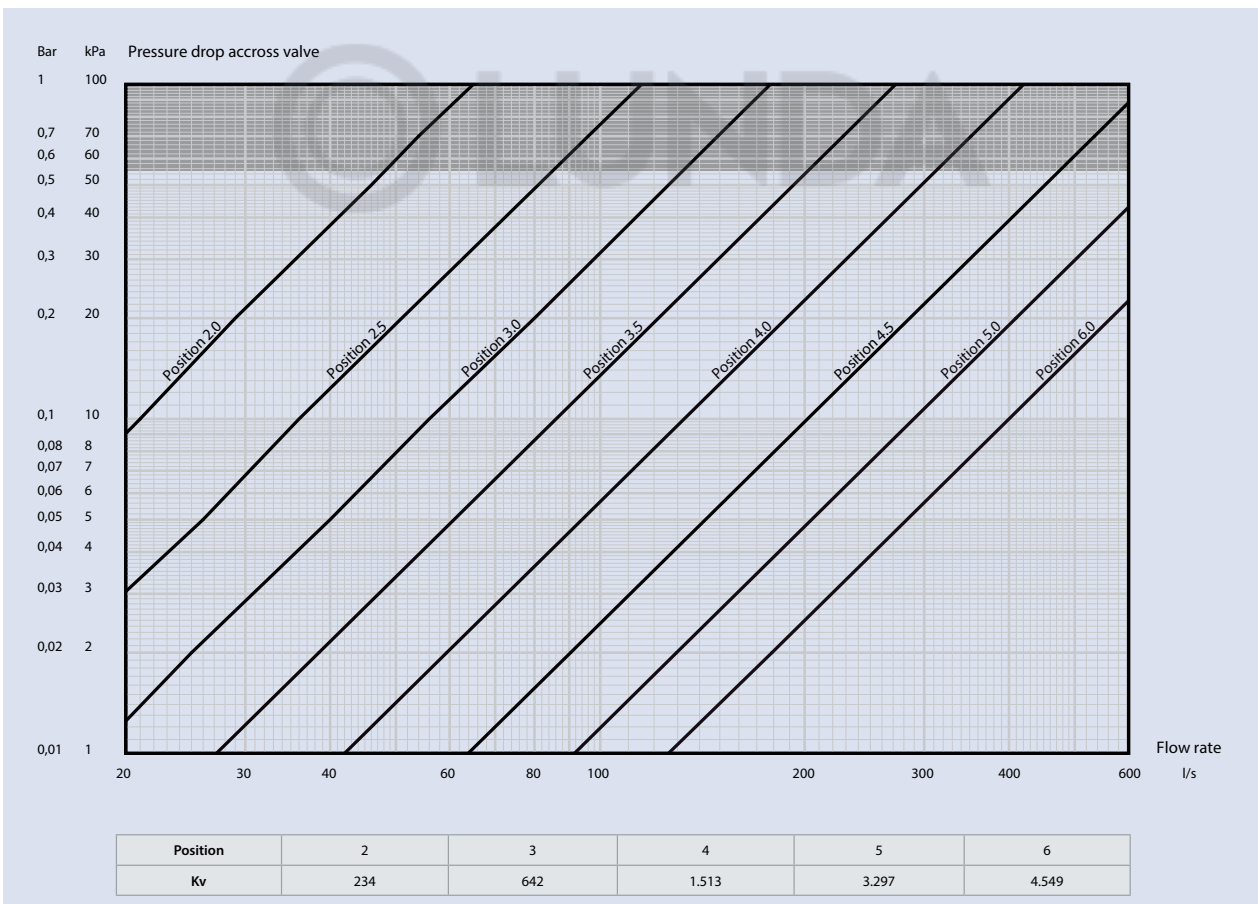

## DN 300

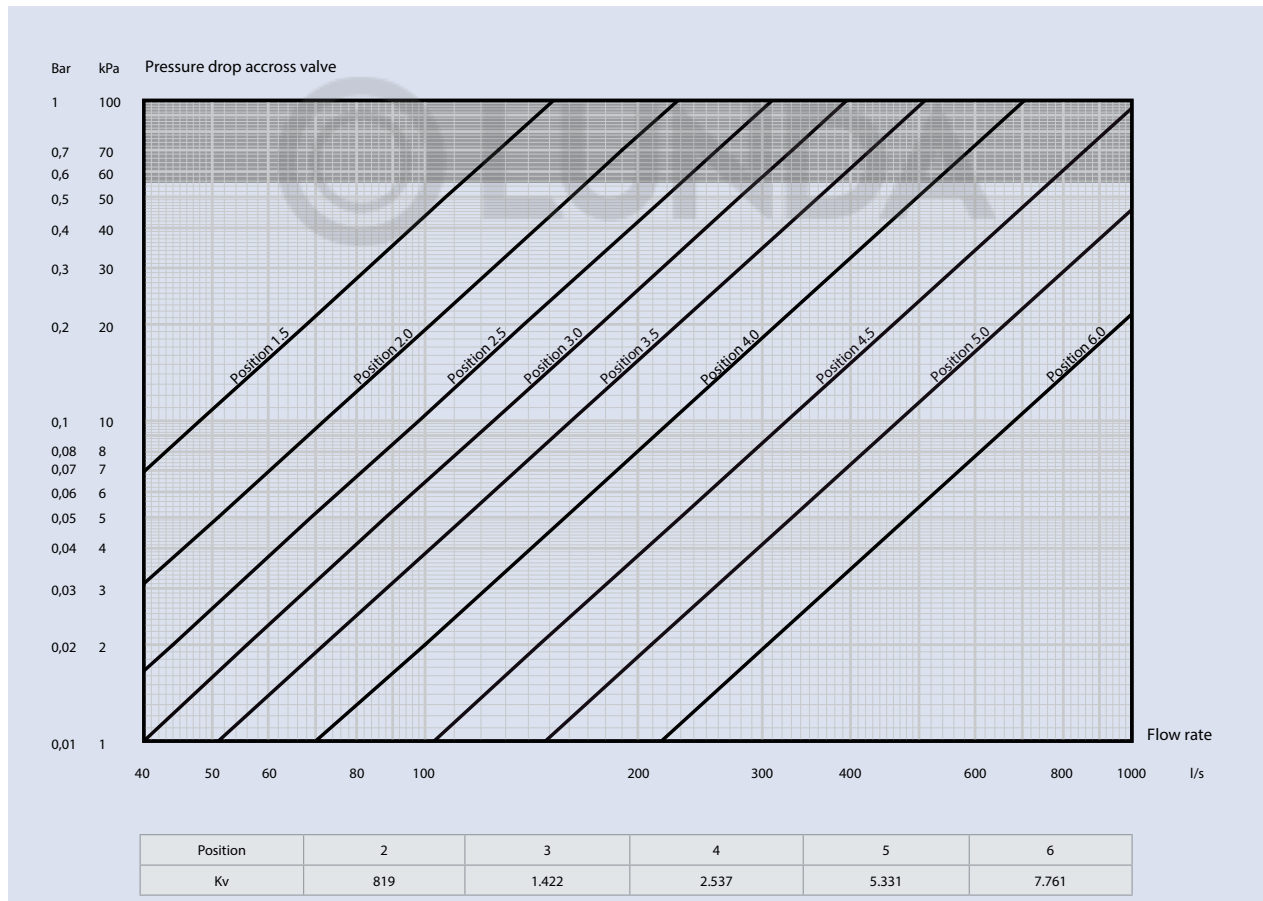

## 5. Accessories

### 5.1 NexusValve Brevis accessories

Accessories	Article	Dimension	Description
	MN80597.7000	DN 15	Insulation jackets for NexusValve Brevis Material: expanded polypropylene Color: anthracite Thermal conductivity: 0,035 W/mK at 10°C Application: up to 110°C Fire protection class: B2, DIN 4102 and E, EN 13501-1
	MN80597.7010	DN 20	
	MN80597.7020	DN 25	
	MN80597.7030	DN 32	
	MN80597.7040	DN 40	
	MN80597.7050	DN 50	
	MN80597.0001	15 mm x 1/2"	Pre-sealed press adaptors (2 pcs) for valve DN 15 -50, max. 16 bar
	MN80597.0002	18 mm x 1/2"	
	MN80597.0003	15 mm x 3/4"	
	MN80597.0004	18 mm x 3/4"	
	MN80597.0005	22 mm x 3/4"	
	MN80597.0006	28 mm x 1"	
	MN80597.0007	35 mm x 1 1/4"	
	MN80597.0008	42 mm x 1 1/2"	
	MN80597.0009	54 mm x 2"	
	MN80597.0205	DN 15	High capacity drain valve (Kv 4,5) 1/2" female/female threaded connection
	MN80597.0206	DN 20	High capacity drain valve (Kv 4,5) 3/4" female/female threaded connection
	MN80597.0207	DN 25	High capacity drain valve (Kv 4,5) 1" female/female threaded connection

## 6. Sizing example

### 6.1 NexusValve Vertex system sizing

The NexusValve Brevis can be used for a number of applications. The following sizing example shows NexusValve Brevis installed in a constant flow system of fan coils. The NexusValve Brevis is to be used in a bypass of a branch with a fan coil. The NexusValve Brevis is to be sized in a way so that the sizing flow can pass through the valve while the pressure loss is the same as in the fan coil.

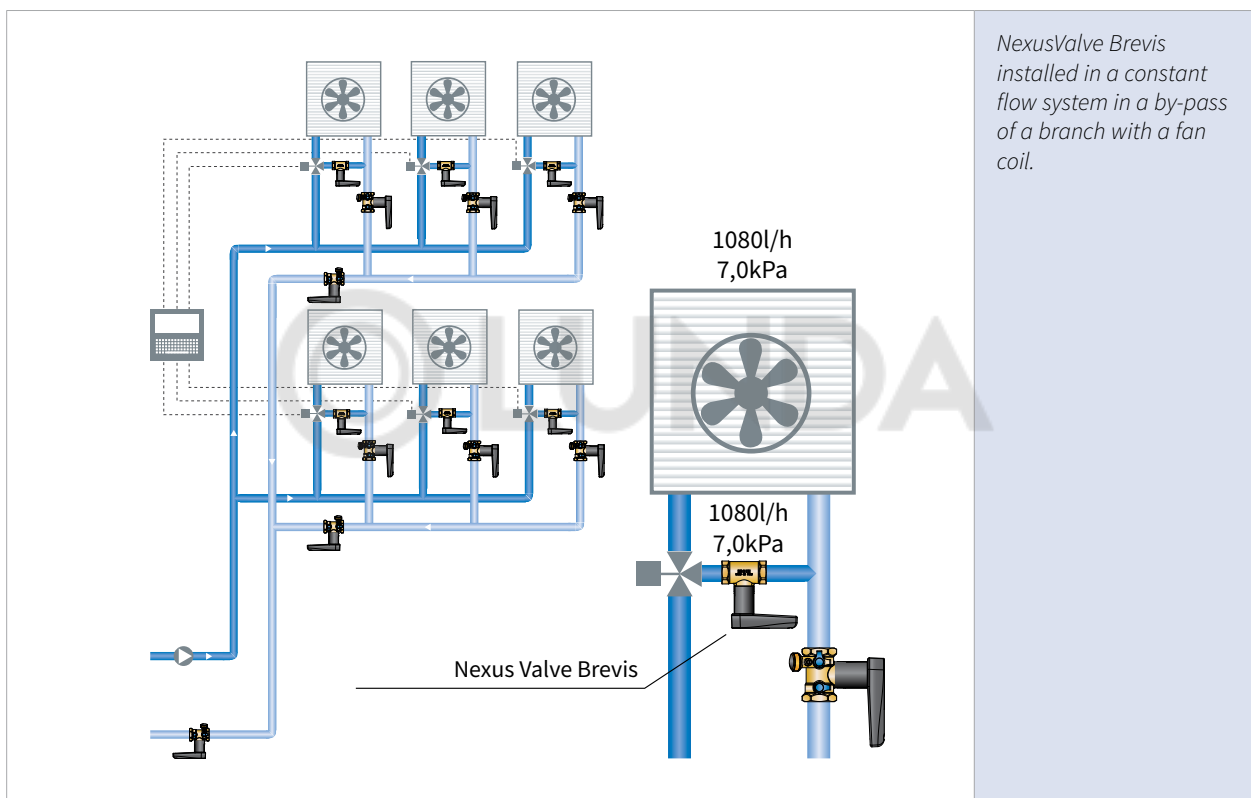

*NexusValve Brevis installed in a constant flow system in a by-pass of a branch with a fan coil.*

The flow to a selected fan coil is specified for the sizing conditions. The fan coil in this example requires 0.30 l/s (1080 l/h). The pressure loss in the circuit with the fan coil at the specified flow has been calculated and is equal 7.0kPa.

Based on this the NexusValve Brevis valve must be sized so that 0.3l/s (1080l/h) at pressure loss 7.0 kPa is ensured when the 3 way valve closes the flow to the fan coil and opens through the by-pass.

Best regulation ability of the NexusValve Brevis (and any static balancing valve) is achieved, when valves are sized to meet the required flow and pressure loss, at fully or nearly fully open position.

The smallest size NexusValve Brevis meeting the requirement is selected. In this case a DN 20S valve at setting 7.0 will ensure the required flow and pressure loss.

The valve of this size will provide good regulation as any setting change will result in a greater pressure loss than for example in the case of a bigger valve like NexusValve Brevis 25S. Consequently it is going to be easier to tune the valve.

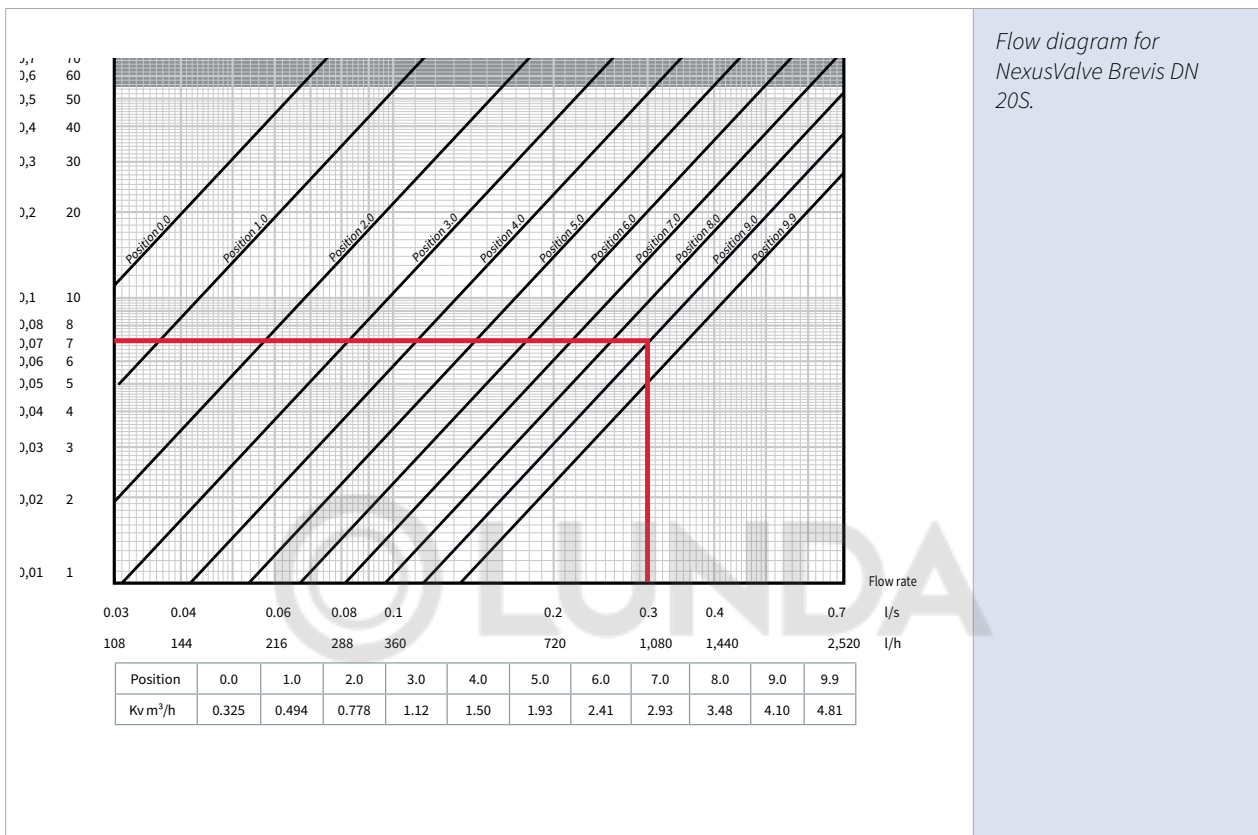

Ordering: NexusValve Brevis article No.: MN80597.444

## 6.2 General specifications DN 10-50

### 1. Balancing valve DN 15 - 50

1.1. The Contractor shall install Static Balancing Valves where indicated in drawings.

### 2. Valve Body – female/female

- 2.1. The valve body shall be made of hot stamped DR brass CW602N CuZn36Pb2As.
- 2.2. The pressure rating shall be no less than PN25 at 135°C.
- 2.3. The valve shall have regulation and isolation in one single unit.

### 3. Flow Regulation

- 3.1. The flow regulation shall be externally adjustable using an Allen key.
- 3.2. The regulation settings shall remain unchanged when the isolation (open/close function) is re-opened.

### 4. Functions

- 4.1. The valve shall have a visible ¼-turn open/close function.
- 4.2. The valve shall have 100 different setting positions.
- 4.3. Valve dimensions shall be clearly marked on the handle.



## Contact

### The Netherlands (HQ)

Aalberts hydronic flow control  
+31 36 52 62 300  
info@flamcogroup.com  
info@comap.nl

### China

Flamco Heating Accessories  
(Changshu) Ltd, Co.  
+86 512 528 417 31  
yecho@flamco.com.cn

### Denmark

Flamco Denmark  
+45 44 94 02 07  
info@flamco.dk

### France

Flamco s.a.r.l.  
+33 1 342 191 91  
info@flamco.fr

### Germany

Flamco GmbH  
+49 2104 80006 20  
info@flamco.de

### Italy

Distributore: Commerciale Delta  
+39 (0)2 242 8303  
vendite@commercialedelta.it

### Slovakia

Flamco SK s.r.o.  
+421 475 634 043  
info@meibes.sk

### Sweden

Flamco Sverige  
+46 50 042 89 95  
vvs@flamco.se

### United Arab Emirates

Flamco Middle East  
+971 4 8819540  
info@flamco-gulf.com

### Belgium

Flamco BeLux  
+32 50 31 67 16  
info@flamco.be

### Czech Republic

Flamco CZ s.r.o.  
+420 284 00 10 81  
info@meibes.cz

### Estonia

Flamco Baltic  
+372 568 838 38  
info@flamco.ee

### France

Comap s.a.r.l.  
+33 4 78 78 16 00  
marketing@comap.eu

### Hungary

Flamco Kft  
+36 23 880981  
info@flamco.hu

### Poland

Flamco Meibes Sp. z o.o.  
+48 65 529 49 89  
info@flamco.pl

### Russian Federation

ООО „Майбес РУС“  
+7 495 727 20 26  
moscow@meibes.ru

### Switzerland

Flamco AG  
+41 41 854 30 50  
info@flamco.ch

### Export

Comap International  
+33 4 78 78 16 00  
export.contacts@comap.eu

Comap BeLux  
+32 2 371 01 67  
info@comap.be

Comap Praha s.r.o.  
+420 284 860 404  
marketing.praha@comap.eu

### Finland

Flamco Finland  
+358 10 320 99 90  
info@flamco.fi

### Germany

Meibes System-Technik GmbH  
+49 342 927 130  
info@meibes.com

Comap Hungária Kft.  
+36 23 503 871  
comap.hungary@comap.eu

Comap Polska Sp. z o.o.  
+48 22 679 00 25  
comap@comap.pl

Comap Россия (офис)  
+7 499 703 33 56  
info.rus@comap.eu

### United Kingdom

Flamco Limited  
+44 17 447 447 44  
info@flamco.co.uk

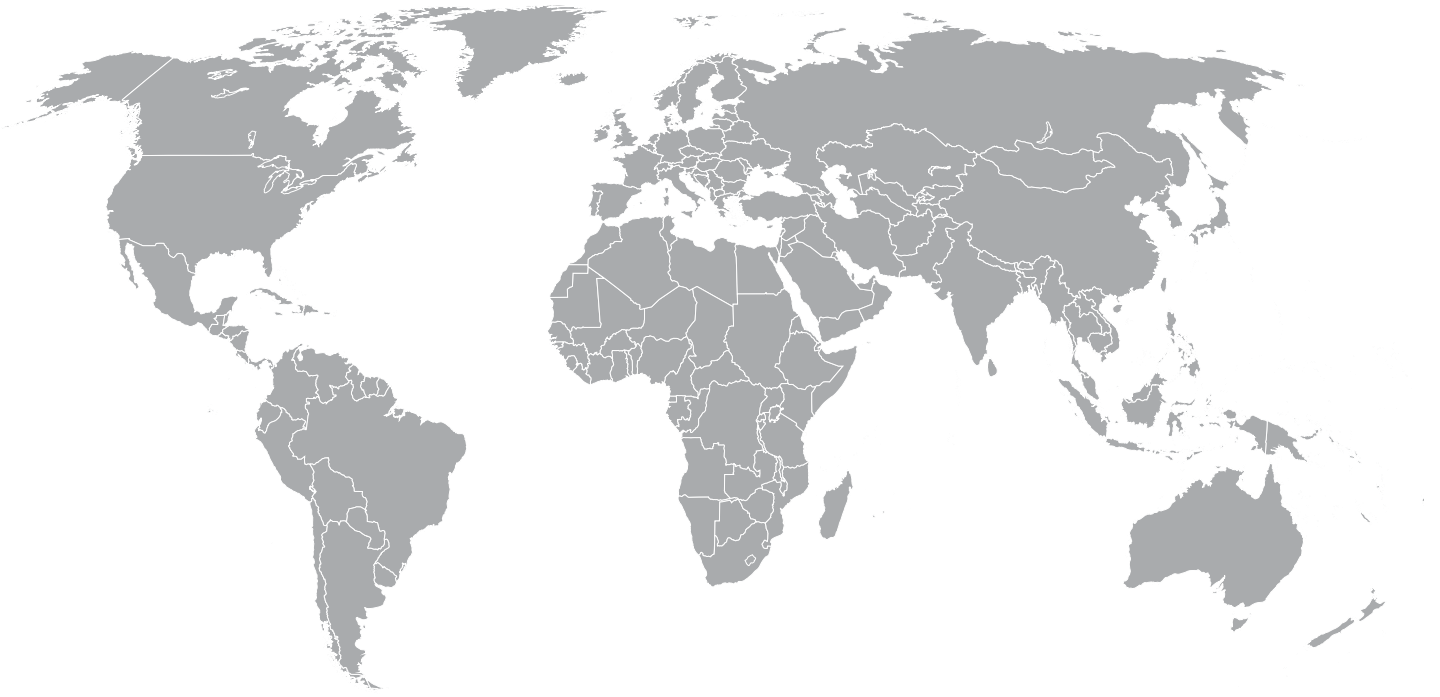

© LUNDA



 **COMAP**  
**Flamco**

Subject to modifications

24004.053 Valid since 2021-07